



Bobcat[®]

One Tough Animal.

POWERED STACKERS

Warehouse Equipment — Walkie, Ride-on platform

🌐 EMEA

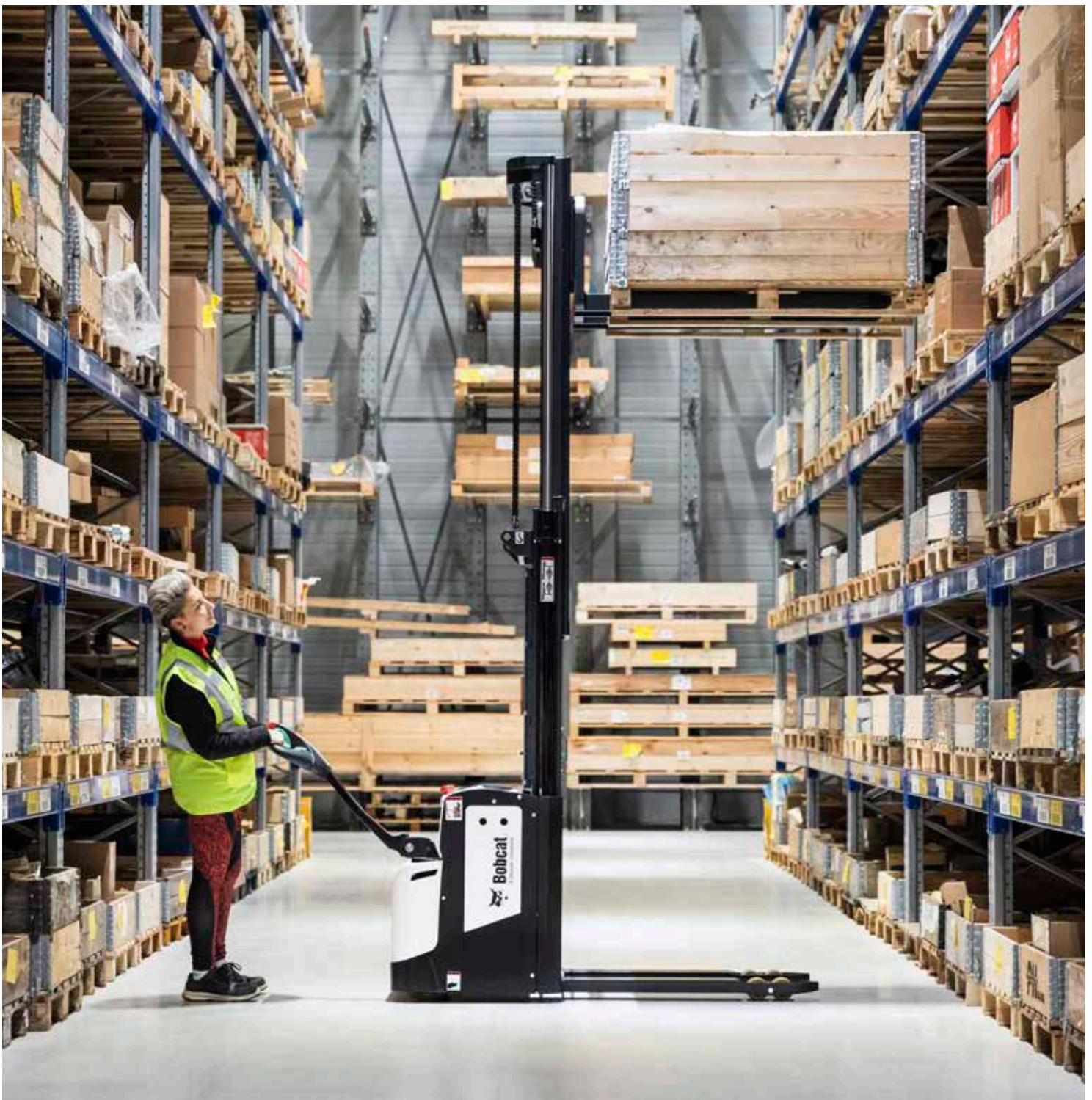

ONE TOUGH ANIMAL



BOBCAT'S HISTORY

In 1958, Melroe Manufacturing Company introduced a compact front-end loader that evolved quickly into the M400, the world's first true skid steer loader. The company soon adopted what became the world-famous 'Bobcat' brand – and its success paved the way for the global compact equipment industry we know today.

YEARS OF EXPERIENCE

In 2021, Bobcat furthered its reach by acquiring Doosan Industrial Vehicle, increasing its capacity to provide customers with comprehensive business solutions. Doosan's expertise in material handling and warehouse equipment, dating back to its inaugural forklift in 1968, enabled the company to establish a global presence with 400 dealers across 93 countries.



BOBCAT TODAY

Now, with a diversified portfolio that includes forklifts and warehouse equipment, Bobcat serves as a one-stop solution for intralogistics needs, from loading shipping containers to optimizing warehouse operations. Produced in its South Korean factory, Bobcat's material handling machines offer the precision and durability customers expect.

OUR MISSION

We empower operators to accomplish more, while working in the toughest conditions and tightest situations. When our customers have the will, we provide the way.



TOUGH, AGILE & SAFE

► THE RIGHT CHOICE FOR YOUR BUSINESS

Discover top-notch efficiency and durability with Bobcat's electric walkie or rider stackers and double stackers. Robustly designed for durability and productivity, these tough and versatile machines offer a capacity between 1–2 tons, and years of reliable operation for your business.



Tiller head features dual butterfly switches, designed to suit every operator's ergonomic needs

Steel cover protects the main components and ensures durability

DIN-type battery in the battery compartment

Excellent visibility through the mast for safer and more efficient work sites

Incremental lifting and lowering speeds for smooth operation and load protection



Monitored and displayed energy levels for uninterrupted and seamless operation

Tandem load wheels help mitigate ground pressure and distribute weight evenly, facilitating smoother pallet entry

Compact and robust design for comfortable and safe operation even in tight spaces

Versatile, foldable platform for a wide range of tasks



► **A DURABLE SOLUTION**
Discover our compact yet powerful walkie and ride-on stackers. Choose options with up to 2 tons of capacity, and experience excellent daily performance with a high-speed AC-powered drive motor.
P. 6–7



► **ALL-DAY COMFORT**
Experience comfortable operation with standard features such as the tiller head and display monitor, ensuring effortless control and a stress-free experience.
P. 8–9



► **DRIVEN BY SAFETY**
Enjoy peace of mind during your shifts with safety features that include speed reduction in specific circumstances, PIN code access, override function, and more.
P. 10–11



► **MAXIMUM UPTIME**
Our stackers and double stackers feature a robust design with a superior steel cover for component protection, quality bearings, and a frame structure with a lifetime warranty.
P. 10–11

OUTSTANDING PRODUCTIVITY



▶ PROPORTIONAL VALVE FOR LIFTING AND LOWERING

Operators can easily control the speed and positioning of the mast during lifting and lowering, enabling gradual adjustments for precise and smooth load handling.

▶ EXCELLENT VISIBILITY THROUGH THE MAST

Improved visibility through the mast allows operators to quickly locate items, accurately position the stacker, and handle loads more efficiently. This reduces maneuvering and positioning time, ultimately speeding up tasks and increasing productivity.



▶ TANDEM LOAD WHEELS & EASY PALLET ENTRY

The contoured fork design and tandem load wheels allow easy entry into, and exit from, palletized loads.

▶ AC POWER

Fully programmable performance parameters allow total customization of acceleration, top speed, and braking.

COMFORT & CONTROLS



▶ ERGONOMIC TILLER CONTROL

Tailored for comfort and versatility, the ergonomically designed tiller arm, equipped with dual butterfly switches, caters to both left- and right-handed operators.



▶ MONITORING DISPLAY

Experience uninterrupted operations with real-time energy and status monitoring on the display. Stay informed about essential updates, ensuring a smooth workflow without any interruptions.



▶ ENJOY ULTIMATE CONTROL

Our pallet trucks offer both central and lateral controls, ensuring seamless maneuvering in any space or warehouse layout.



▶ FOLDABLE PLATFORM

Operators can easily adjust the platform to their preferred height, promoting better posture and reducing strain during prolonged operation. Additionally, the foldable feature ensures easy access to the load in tight spaces.



▶ EASY CONTROLS

The ergonomic tiller arm features height and length adjustment allowing operators to find the perfect position.



▶ ROLL OUT BATTERY

Nylon rollers make it easy to remove the battery, simplifying the battery exchange process.

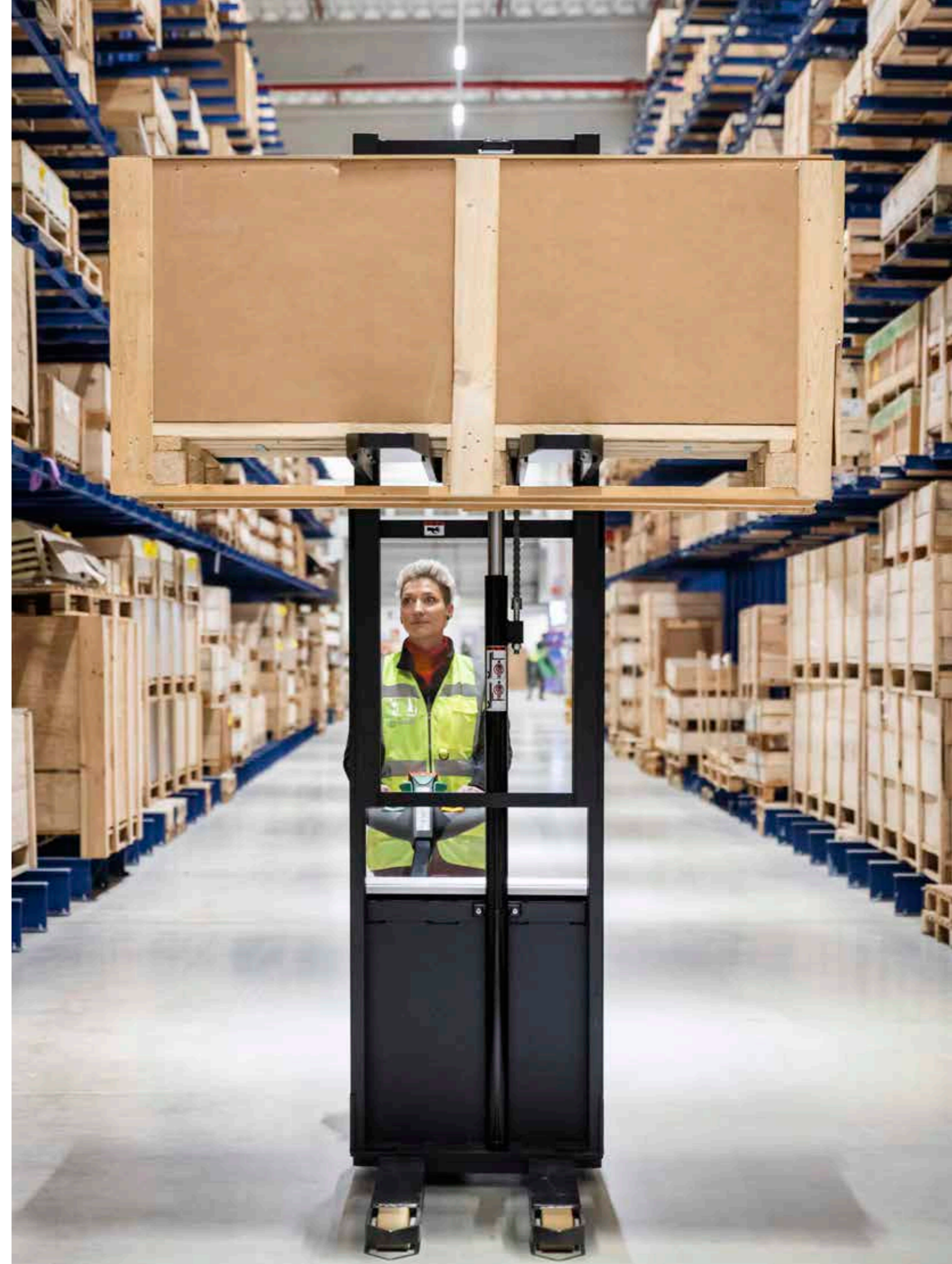

SAFETY IN EVERY MOVE

▶ ADVANCED PROTECTION FOR YOU AND YOUR OPERATION

Bobcat warehouse equipment has safety embedded in its DNA. Packed with features that protect your health and your investment, these machines give you peace of mind in every task, every day.

▶ OVERRIDE FUNCTION

With the simple push of a button on the tiller head, this feature offers more precise control in confined spaces by slowing down the truck while handling loads.

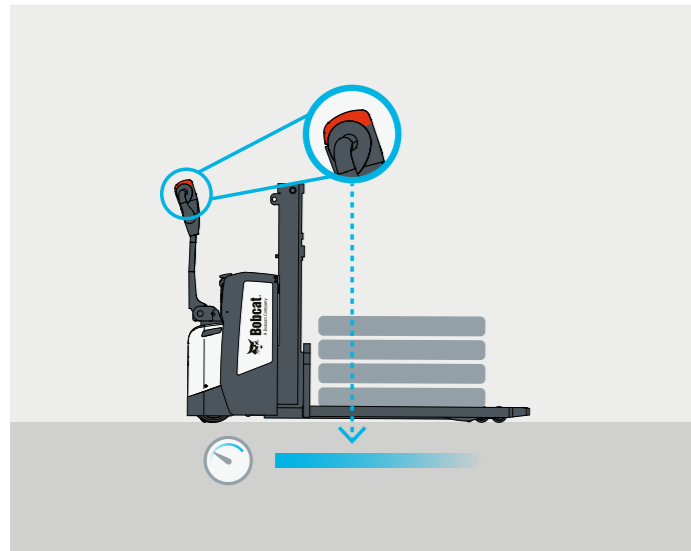

▶ SPEED-REDUCING KIT FOR CORNERING

When approaching and navigating corners, this adjustment ensures smoother and more secure operations, reducing the likelihood of accidents and potential damage to the machine (for ride-on units only).

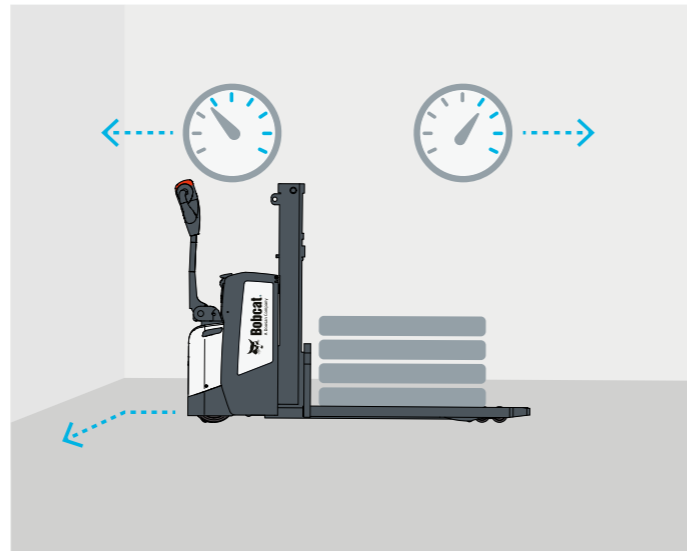

▶ TURTLE SPEED SWITCH

The turtle speed switch allows extremely slow and controlled movement, offering greater accuracy and caution. This feature proves useful when handling fragile or sensitive materials, or when navigating confined spaces that require precise control.

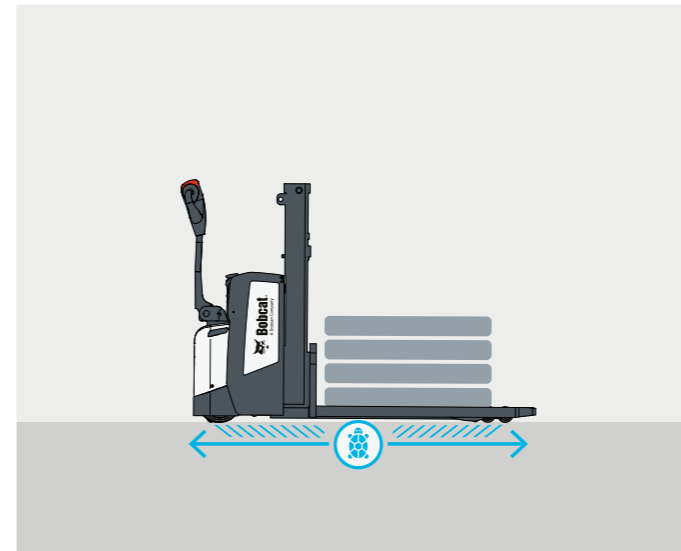

▶ PIN CODE ACCESS

By protecting the machine from unauthorized use, pin code access adds security to your job site.



▶ EMERGENCY SWITCH

Operators can quickly deactivate the truck by pressing the emergency switch, reducing the time it takes to identify the issue and take necessary action.

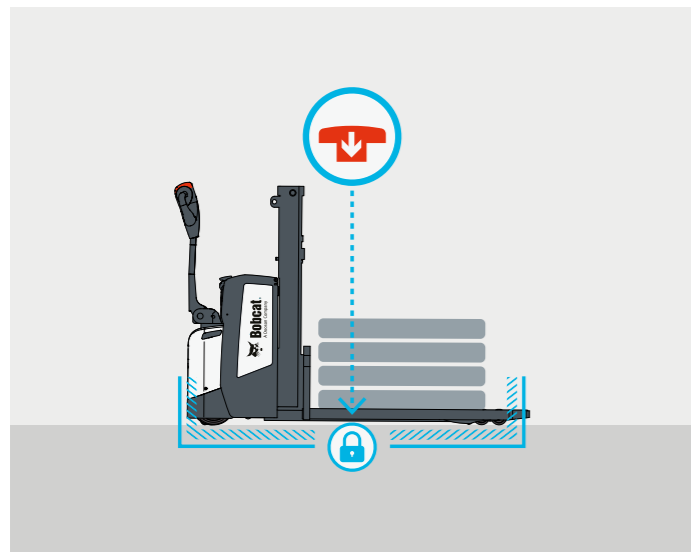

▶ SPEED REDUCTION WITH LIFTED MAST

Reducing mast lifting speed decreases the likelihood of accidents and instability, especially when handling heavier loads. This feature reduces the mast lifting speed when the mast is lifted over 1 meter in height.

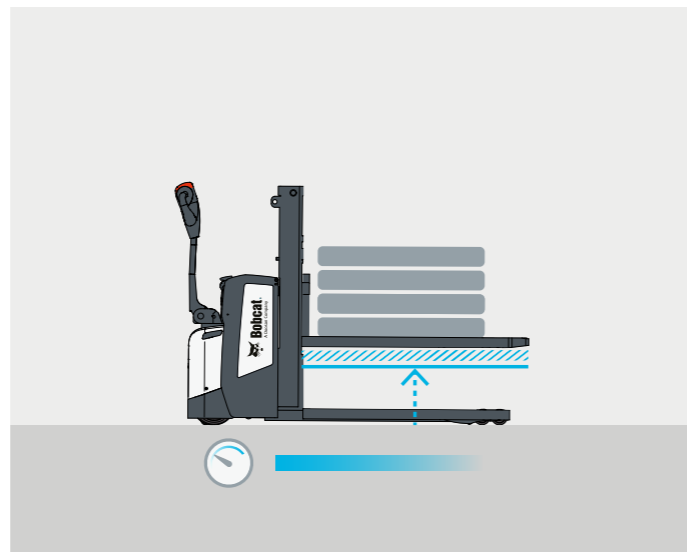

▶ LOAD BACK REST

The load back rest provides a protective barrier between the operator and the load, minimizing the possibility of loads sliding back and causing injuries.



▶ SMOOTH LOAD LOWERING

Our stackers use hydraulic technology to gently and smoothly lower lifted loads to the ground, preventing sudden jolts or impacts and enhancing safety.



BUILT TO LAST

▶ EXCELLENT RELIABILITY

With a robust design, powerful AC motor, and combined bearings, Bobcat warehouse equipment is built tough, offering you maximum uptime and dependability.



THERE'S NO TIME FOR DOWNTIME. STAND UP TO EVERY TASK THAT COMES YOUR WAY, DAY AFTER DAY.



▶ LIFETIME WARRANTY

Bobcat develops each machine to the highest standards of quality and durability. That's why we provide a lifetime guarantee on the frame structure (10 years) to ensure our trucks deliver maximum reliability and usage.



▶ EXTENSIVE DEALER NETWORK

You can rely on our network of dealers and service partners who are always ready to help you.

▶ BOBCAT GENUINE PARTS

Quality components delivered to our dealers guarantee that all of our equipment is built to last, withstand the toughest conditions, and provide reliable performance.



STANDARD EQUIPMENT & OPTIONS

STANDARD EQUIPMENT & OPTIONS	BSL10/13S-7C	BSL14/16S-7	BSR16S-7	BSL20S-7	BDL13S-7	BDR13S-7
PRODUCTIVITY						
Display for monitoring energy and machine status	✓	✓	✓	✓	✓	✓
Mechanical steering	✓	✓	–	✓	✓	–
Tandem load wheels	•	✓	✓	✓	•	✓
Chassis for 3EPzS Battery, max 375 Ah, L2 = 810 mm	–	•*	–	✓	–	–
Battery Roll-in/Roll-out system	–	✓	✓	✓	–	–
Integrated charger 24V / 30A	•	•	–	–	•	–
Integrated charger 24V / 40A	–	•	–	•	–	–
Cold store version (down to -30 °C)	•	•	•	•	•	–
Special frame coating	•	•	•	•	•	–
Final painting	•	•	•	•	•	–
Stainless steel axles and bolts	•	•	•	•	•	–
Greasable cross-bearings with special lubricant (down to -30 °C)	•	•	•	•	•	–
Special hydraulic oil (down to -30°C)	•	•	•	•	•	–
Magnetic brake heating system	•	•	•	•	•	–
FORKS & MASTS						
Forks 1 195 / 570 mm	✓	✓	✓	✓	✓	✓
Standard (STD), 690 mm	–	–	–	–	•	–
Standard (STD), 1 790 mm	•	–	–	–	•	•
Standard (STD), 2 090 mm	•	–	–	–	•	•
Standard (STD), 2 490 mm	•	–	–	–	•	–
Standard (STD), 2 890 mm	•	•	•	•	–	–
Standard (STD), 3 290 mm	•	–	–	–	–	–
Standard (STD), 3 590 mm	•	•	•	•	–	–
Full Free (FF), 2 890 mm	–	•	•	–	–	–
Full Free (FF), 3 590 mm	–	•	•	–	–	–
Full Free Triple (FFT), 4 190 mm	–	•	•	•	–	–
Full Free Triple (FFT), 4 390 mm	–	•	•	•	–	–
Full Free Triple (FFT), 4 790 mm	–	•	•	•	–	–
Full Free Triple (FFT), 5 390 mm	–	•	–	•	–	–
RELIABILITY						
Stainless steel axles and bolts	•	–	–	–	•	–
Steel cover	•	•	–	•	•	–
Vulkollan™ drive wheels with tread	•	•	–	–	•	–
PEVOSOFT™ drive wheels	•	–	–	–	•	–
SAFETY						
Pin code access	✓	✓	✓	✓	✓	✓
Turtle speed switch	✓	✓	✓	✓	✓	✓
Load Back rest 1 000 mm	–	•	•	•	–	–
Speed reduction when mast is lifted over 1 m height	–	•	✓	•	–	–
Speed reduction kit for cornering	–	–	✓	✓	–	✓

* only available with FF and FFT Mast

• = option
 ✓ = standard
 – = not available



Tandem load wheels



Pin code access



Magnetic brake heating system



Turtle speed and emergency switch



Durable design with special frame coating



Reliable Curtis AC controller

MAIN SPECIFICATIONS

STACKERS						
MODEL		BSL10S-7C	BSL13S-7C	BSL14S-7	BSL16S-7	BSL20S-7
Operator type		compact walkie		heavy walkie		
Load capacity / rated load center (kg)	Q	1 000	1 250	1 400	1 600	2 000
Load center (mm)	c	600				
Load distance (mm)	x	787		735		735
Wheelbase (mm)	y	1 318	1 326		1 397	1 397
Tires		Vulkollan™				
Tread, front (mm)	b10	390		525		
Tread, rear (mm)	b11	385				
Lift height (mm)	h3	1 790 – 3 590		2 890 – 5 390		
Height tiller, in drive position (mm)	h14	1 250		1 260		
Height, lowered (mm)	h13	90				
Overall length (mm)	l1	1 870	1 928		2 000	
Length to forkface (mm)	l2	674	732		805	
Overall width (mm)	b1	660		790		
Fork dimensions (mm)	s / e / l	55 / 185 / 1 195		65 / 185 / 1 195		70 / 185 / 1 195
Distance over forks (mm)	b5	570				
Ground clearance, center of wheelbase (mm)	m2	32		25		20
Aisle width for pallets 800 × 1 200 lengthways (mm)		2 256		2 301		2 371
External turning radius (mm)	Wa	1 481		1 490		1 560
Travel speed, loaded (km/h)		5.5		6		
Lift speed, loaded / unloaded (mm/s)		150 / 210		130 / 200		110 / 200
Lowering speed, loaded / unloaded (mm/s)		530 / 240		490 / 280		
Max. gradeability, loaded / unloaded (%)		7 / 12				
Service brake		electric				
DC – lift motor (kW)		1.4		3		1

Specification values in this sheet have been rounded. Performance may vary depending on operating conditions. Products and specifications are subject to improvement and change without prior notice.

(1) Mast dimensions refer to a range from the lowest to the highest available mast.

SPECIFICATIONS

BSL10S-7C / BSL13S-7C

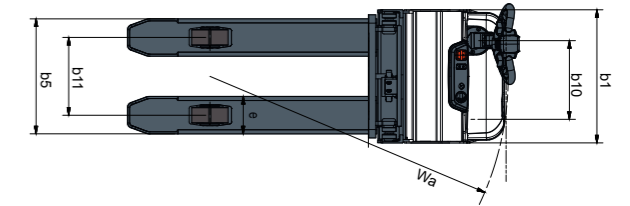
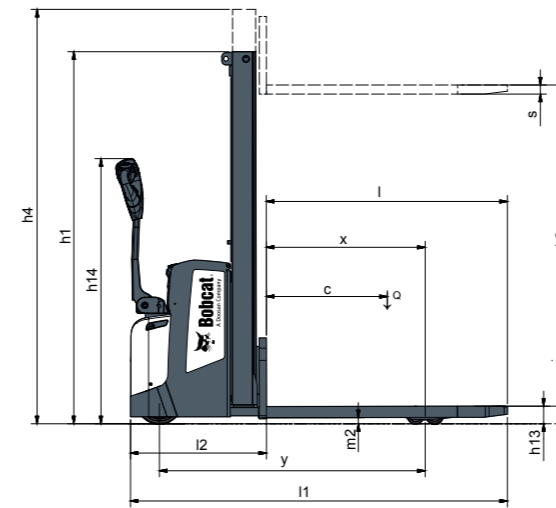

BSL14S-7

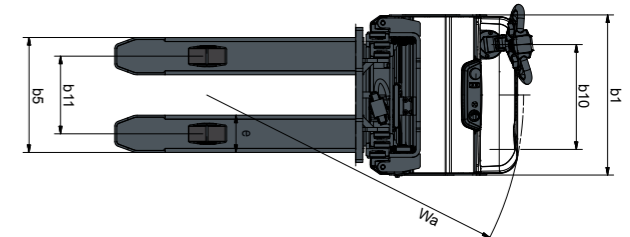
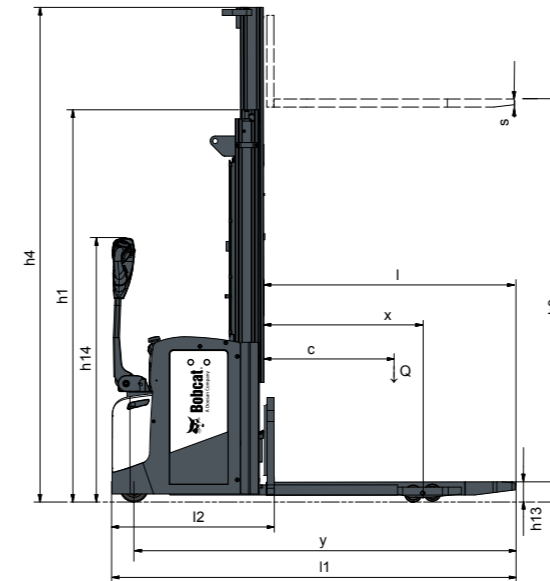

BSL16S-7 / BSL20S-7

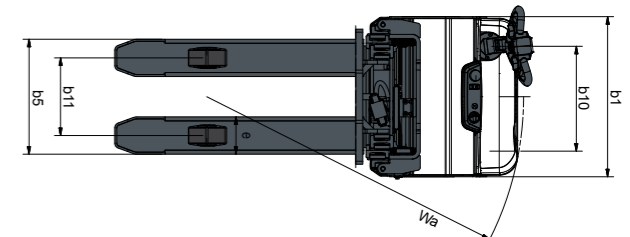
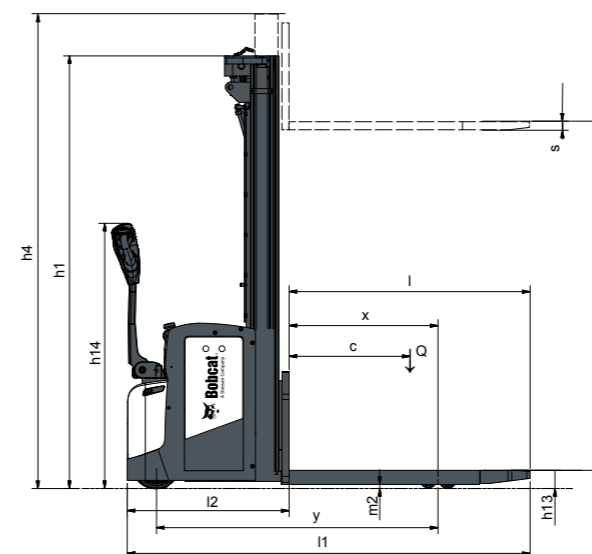

MAIN SPECIFICATIONS

STACKERS				
MODEL		BSR16S-7	BDL13S-7	BDR13S-7
Operator type		platform	walkie	platform
Load capacity / rated load center (kg)	Q	1 600	1 250 / 1 800	
Load center (mm)	c		600	
Load distance (mm)	x	740	980	984
Wheelbase (mm)	y	1 450	1 512	1 697
Tires			Vulkollan	
Tread, front (mm)	b10	468	375	468
Tread, rear (mm)	b11		385	
Lift height (mm)	h3	2 890 – 4 790	690 – 2 490	1 790 – 2 090
Height tiller, in drive position (mm)	h14	1 163	1 260	1 162
Height, lowered (mm)	h13		90	
Overall length (mm)	l1	2 116	1 860	2 109
Length to forkface (mm)	l2	921	660	914
Overall width (mm)	b1	787	660	700
Fork dimensions (mm)	s / e / l	65 / 185 / 1 195		55 / 185 / 1 195
Distance over forks (mm)	b5		570	
Ground clearance, center of wheelbase (mm)	m2	25	35	25
Aisle width for pallets 800 × 1 200 lengthways (mm)		2 471	2 327	2 323
External turning radius (mm)	Wa	1 677	1 670	1 906
Travel speed, loaded (km/h)		9 / 10	5.6	8 / 9.5
Lift speed, loaded / unloaded (mm/s)		130 / 200	150 / 230	120 / 240
Lowering speed, loaded / unloaded (mm/s)		490 / 280	500 / 260	450 / 260
Max. gradeability, loaded / unloaded (%)		7 / 12	8 / 10	6 / 8
Service brake			electric	
DC – lift motor (kW)		2.3		1.4

Specification values in this sheet have been rounded. Performance may vary depending on operating conditions. Products and specifications are subject to improvement and change without prior notice.

(1) Mast dimensions refer to a range from the lowest to the highest available mast.

SPECIFICATIONS

BSR16S-7

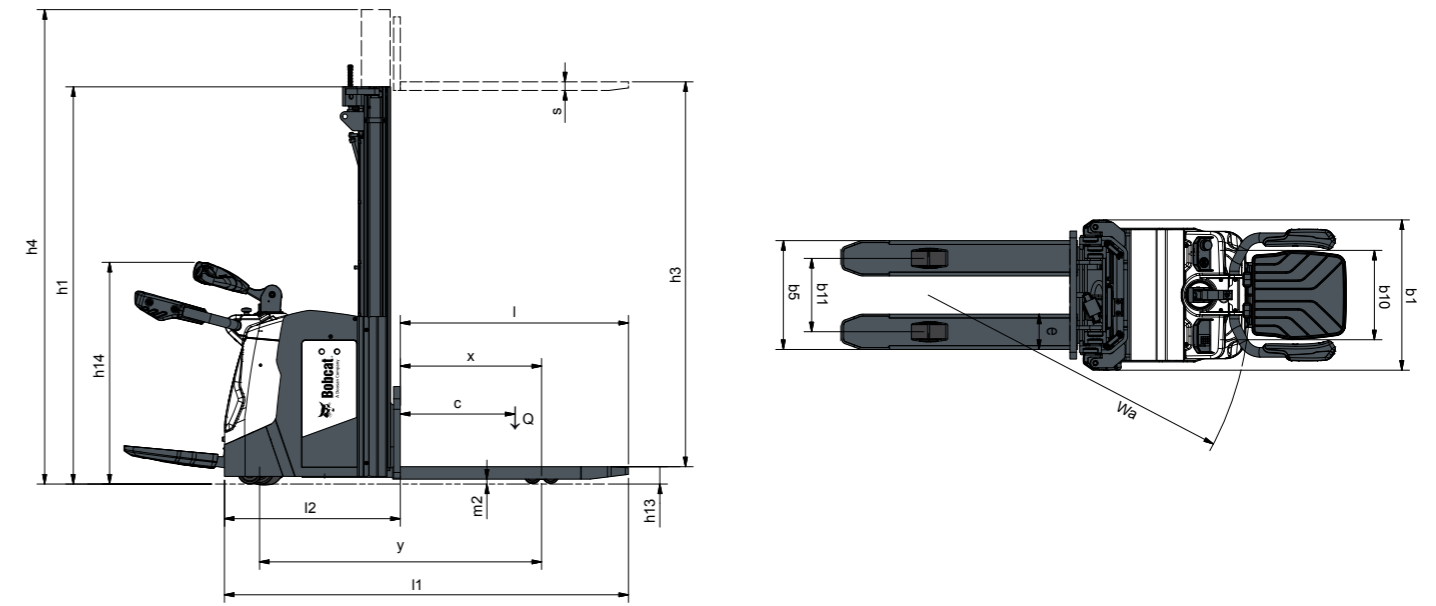

BDL13S-7

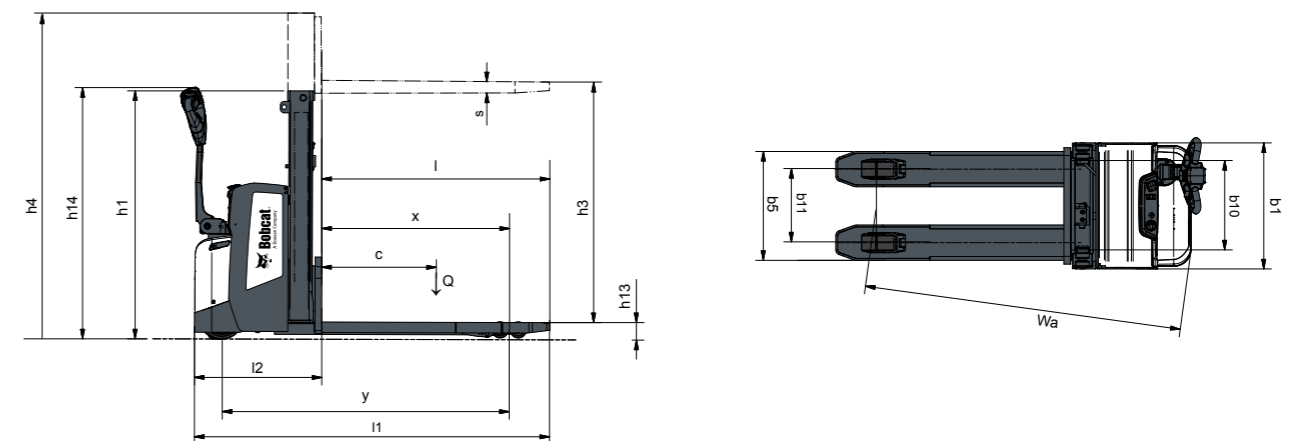

BDR13S-7

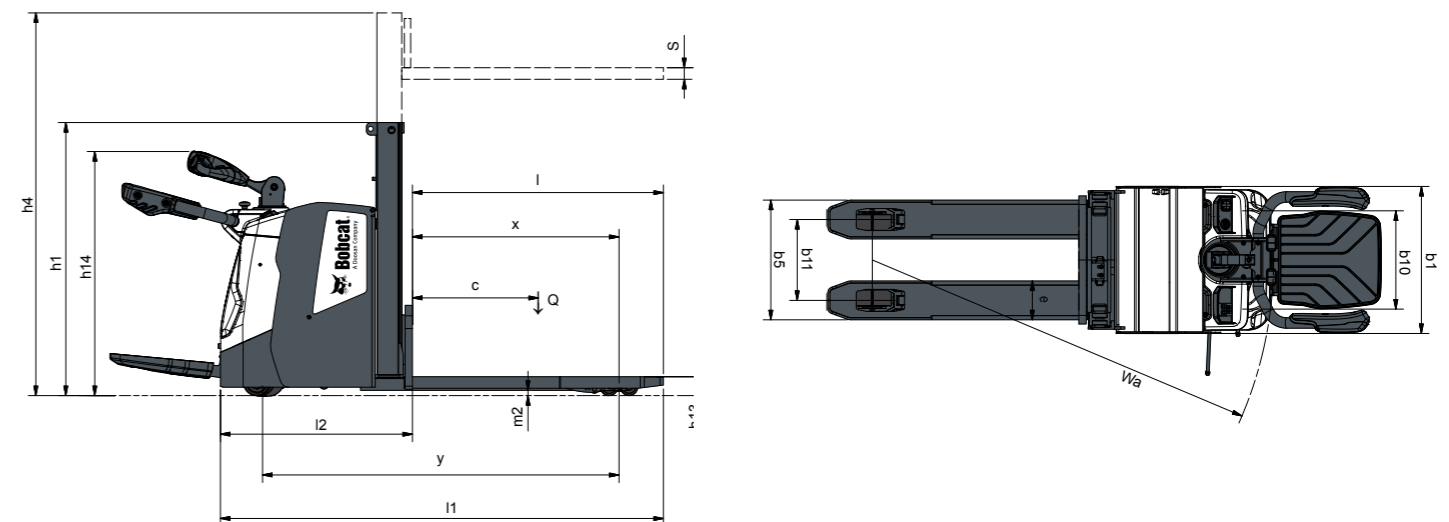

FINANCING OPTIONS

24, 36, OR 48 MONTH FINANCING*

Take advantage of 24, 36 or 48 month financing programs starting from **0% interest** and improve your cashflow.

Ask your dealer for the financing offers available.

340 MACHINES / 150 ATTACHMENT FAMILIES / 1 TOUGH ANIMAL



**SKID-STEER
LOADERS**



**COMPACT TRACK
LOADERS**

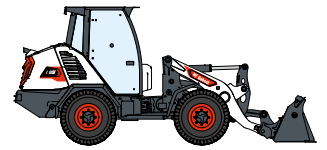

**COMPACT WHEEL
LOADERS**



FORKLIFTS

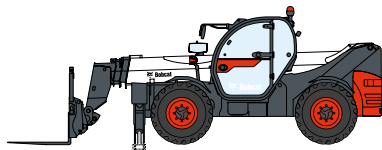

TELEHANDLERS

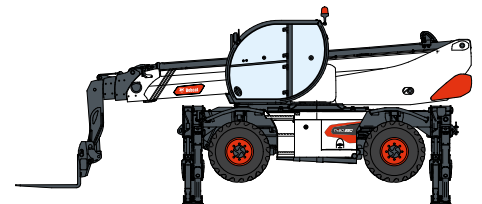

ROTARY TELEHANDLERS



**LIGHT COMPACTION
EQUIPMENT**



**COMPACT
EXCAVATORS**



**COMPACT
TRACTORS**

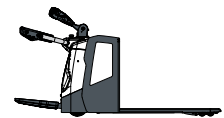

**WAREHOUSE
EQUIPMENT**



**MINI TRACK
LOADER**



MOWERS



**PORTABLE
POWER**

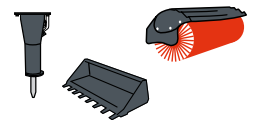

ATTACHMENTS

DOOSAN

Bobcat is a Doosan Company. Doosan is a global leader in construction equipment, power & water solutions, engines, and engineering proudly serving customers and communities for more than a century. | Bobcat and the Bobcat logo are registered trademarks of Bobcat Company in the United States and various other countries. ©2024 Bobcat Company. All Rights Reserved.

www.bobcat.com

©2024 BOBCAT B4502760-EN (03-24)



Bobcat®

*Financing options may vary by country and dealer. Always ask your dealer about currently available financing options. Terms and conditions may apply.

Doosan Bobcat EMEA, U Kodelky 1810, 263 12 Dobříš, Czech Republic