

CATALOG PRODUSE EURO STAR ALUMINIU s.r.l. BACAU



BALUSTRADE



RAME USI STICLA



PROFILE MOBILIER PAL



PROFILE TRECERE

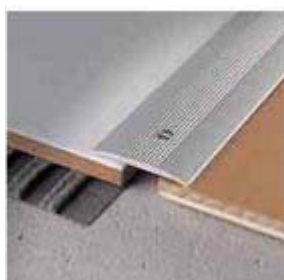

PROTECTIE TREPTE



CORNIERE SI TEVI ELOXATE



SISTEME USI GLISANTE



**PUBLICITATE SI SPATII
COMERCIALE**



PROFILE PT CONSTRUCTII



PROFILE INDUSTRIALE



BALUSTRADE si accesorii aferente..

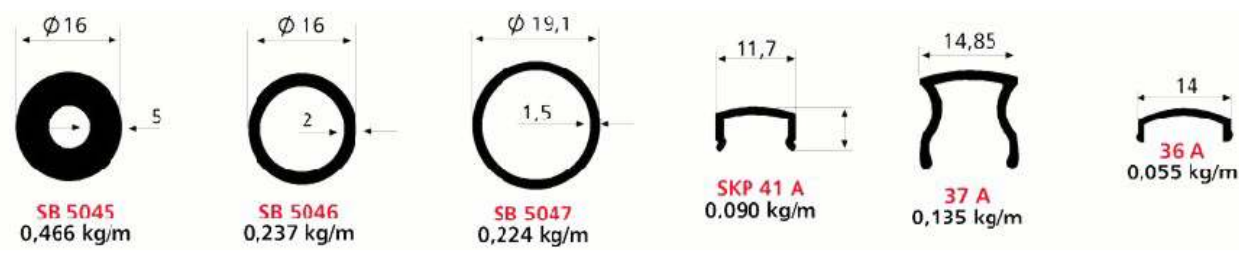
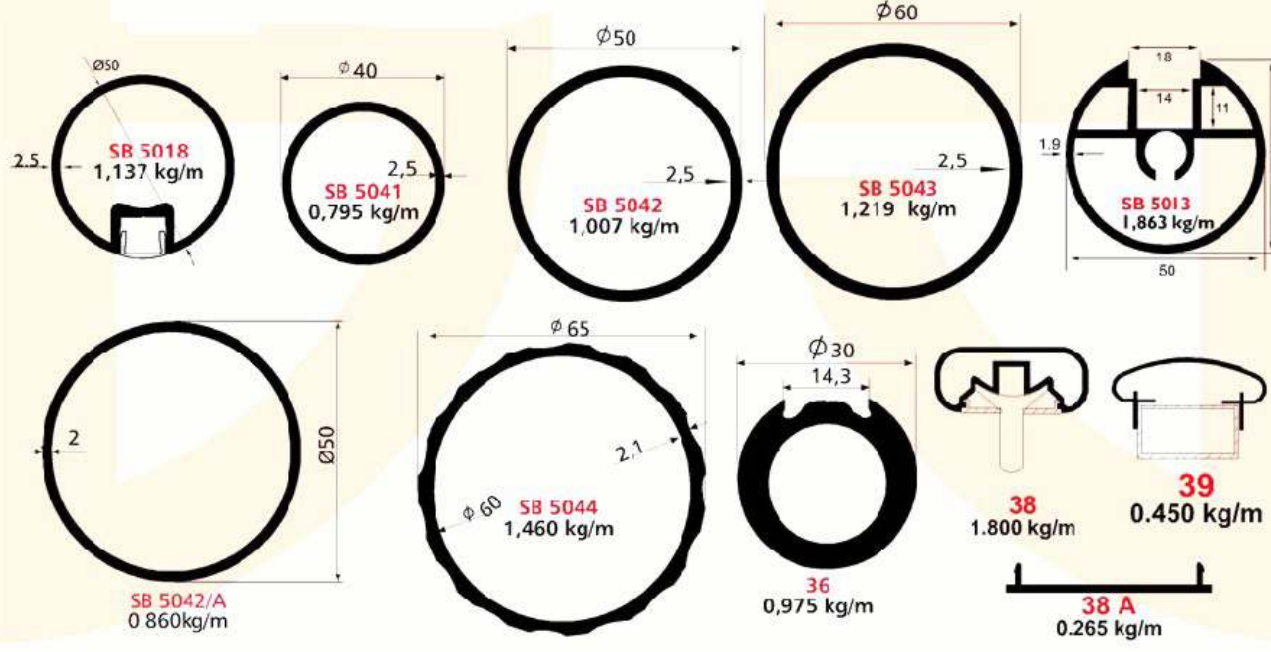
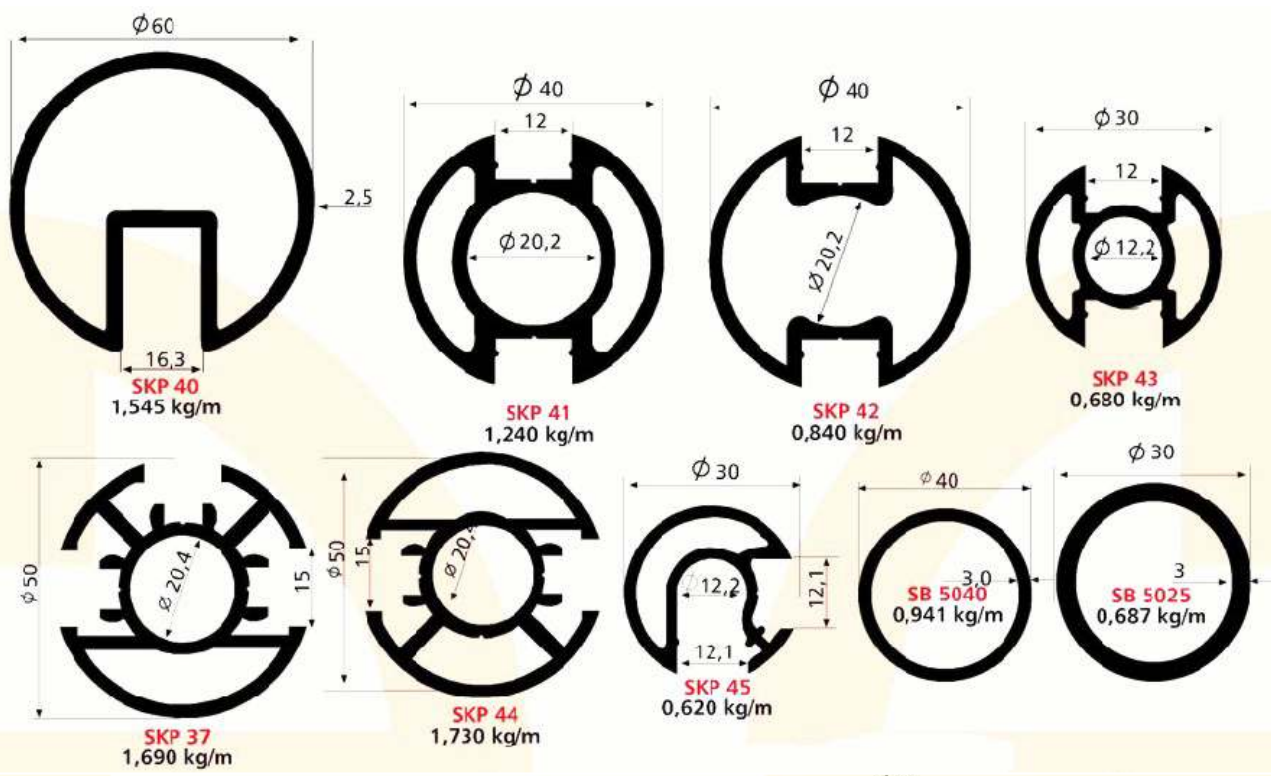

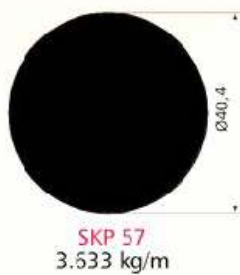
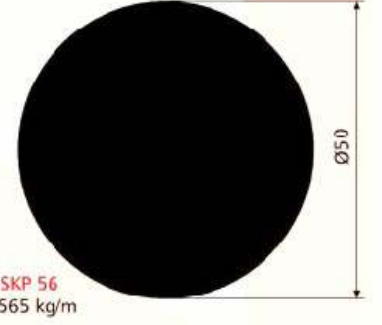
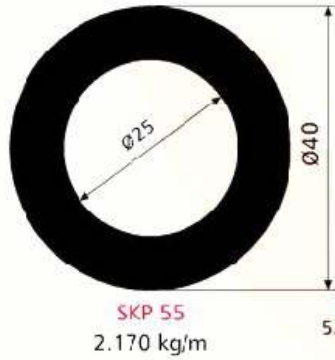
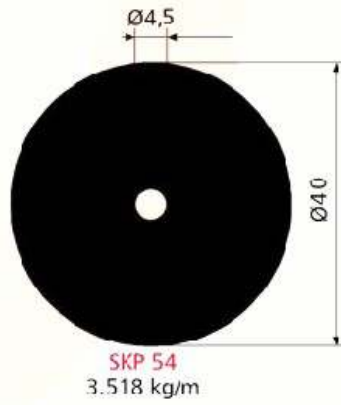
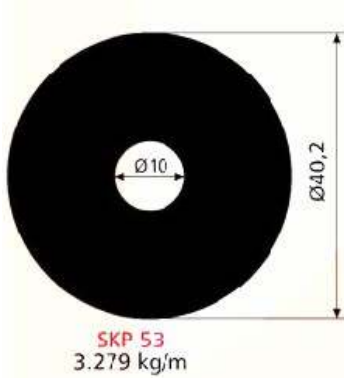
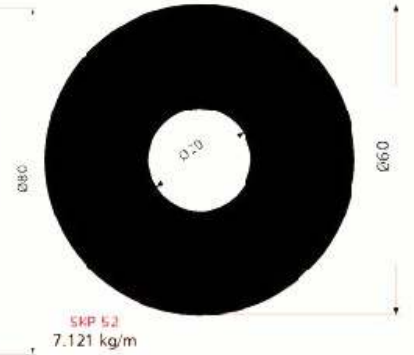
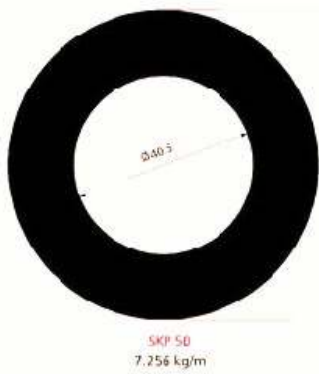
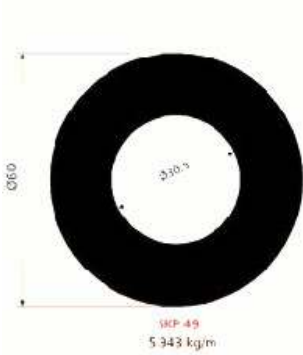
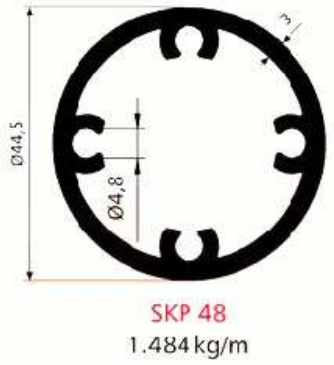
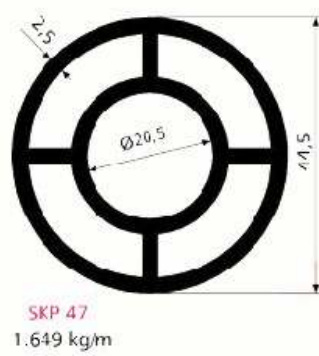
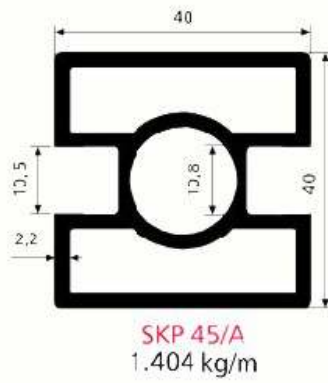
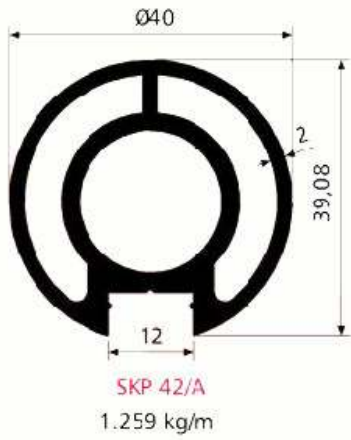



6.inel decor pt 55
8.piesa prindere laterala montant
55.piesa prindere laterala
56,57.distantiere pt prinderea laterala



5.articulatie semiluna pt 40'
12.articulatie parte inferioara montant
22.dop 40' legatura articulatie
28.bulon prindere



sistem prindere mana curenta-perete

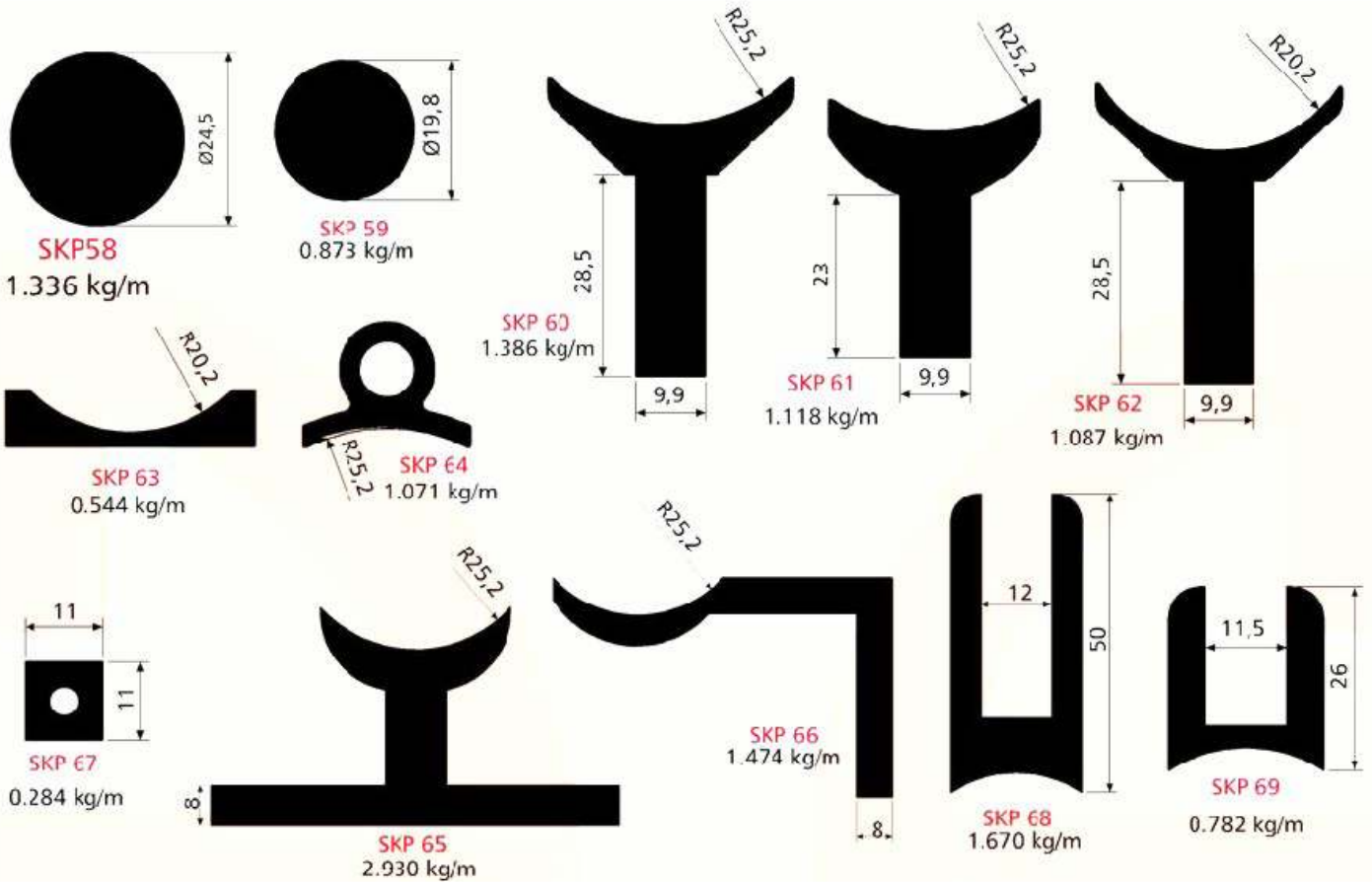

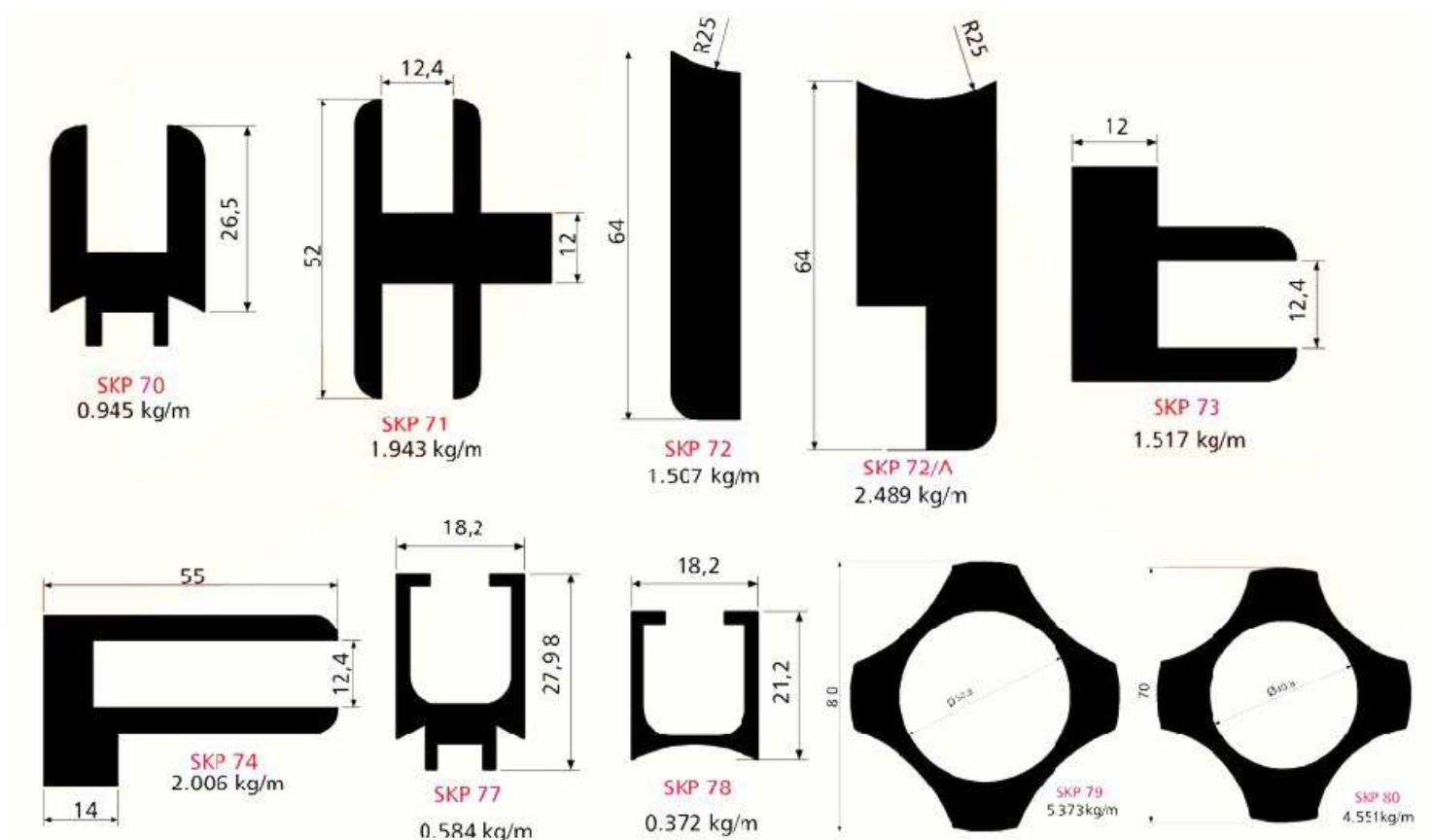

24.dop 30'
 25.dop 50'
 26.dop 16'
 27.dop 40'
 77.dop 60'
 78.dop 40'



16.inel mascare imbinare 16'
 17.inel mascare imbinare 50'
 64.inel mascare imbinare 40'
 63.inel mascare imbinare 60'



- 1.montant 40'
- 2.mana curenta 50'
- 3.bara decor 16'
- 4.ornament montant
- 37.mana curenta 40'
- 42.mana curenta 60'



- 9.clips prindere sticla
- 11.pana pt sticla
- 49.clips prindere sticla

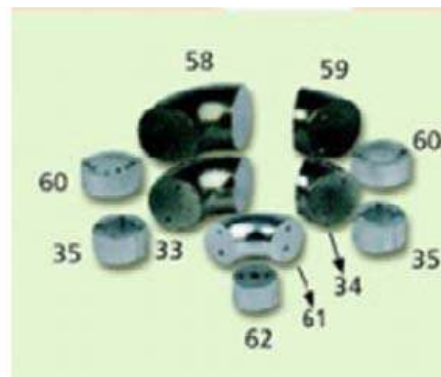

coturi 45/90 pt mana curenta de 40' si 50'

RAME si USI de STICLA..

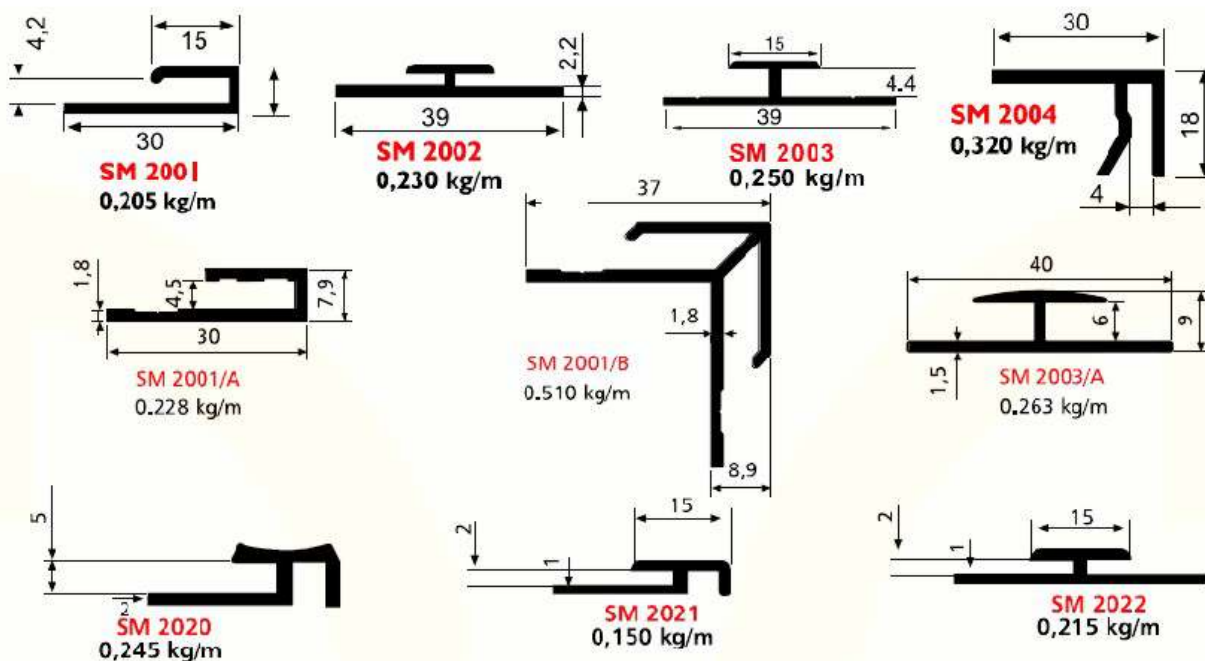

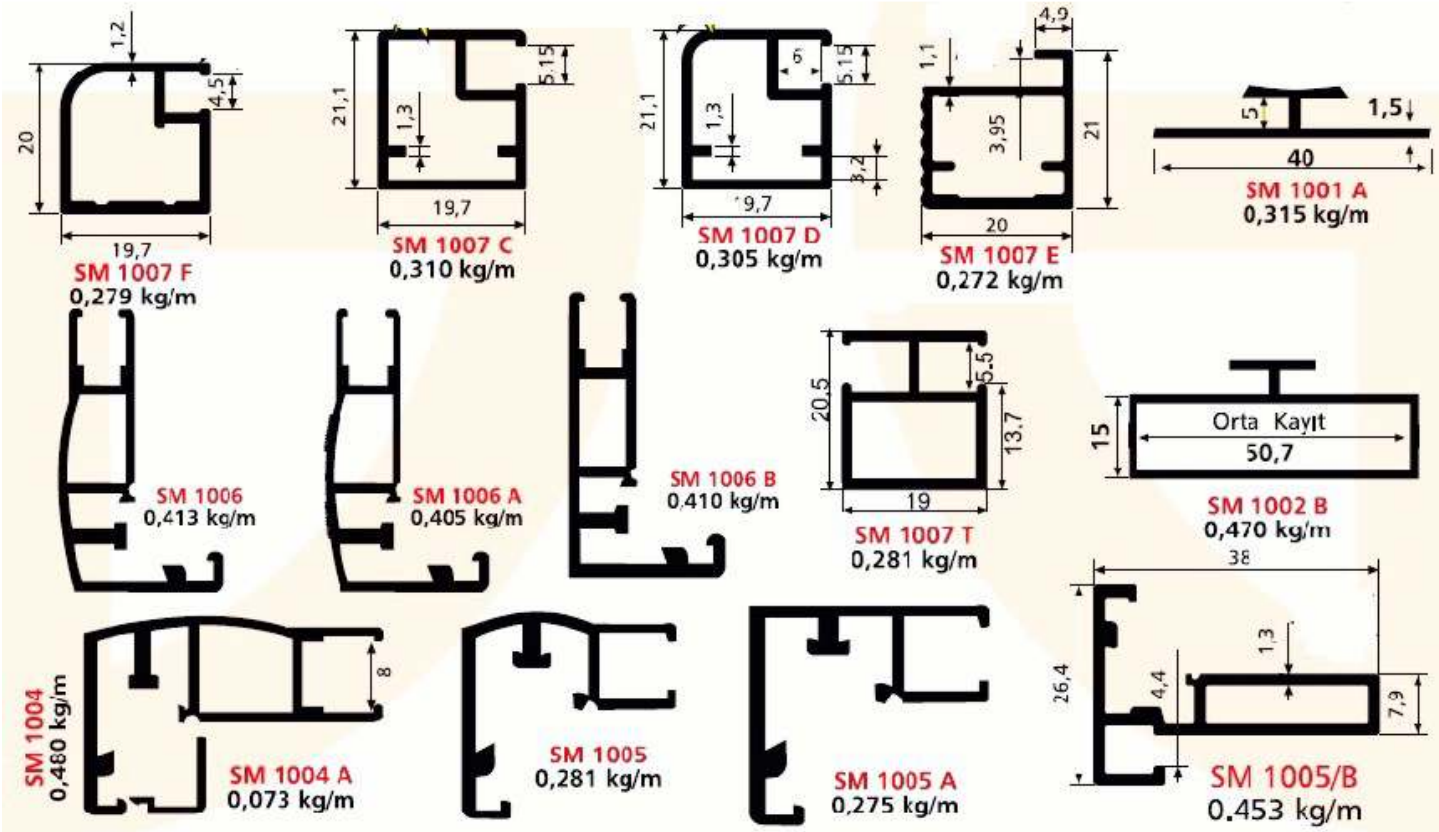
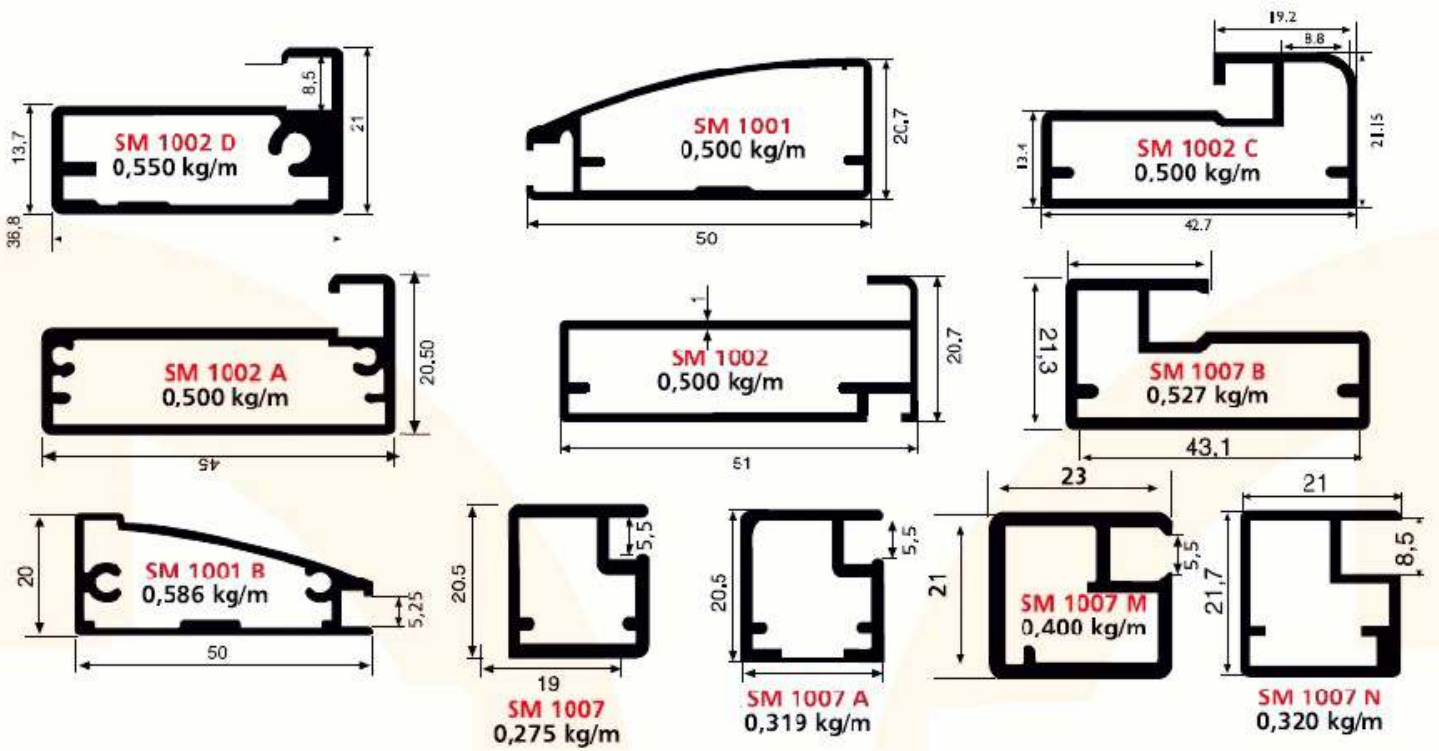

SM 1004
0,480 kg/m

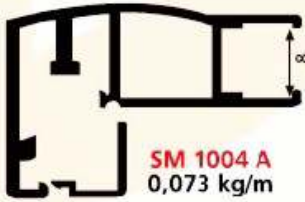

SM 1004 A
0,073 kg/m

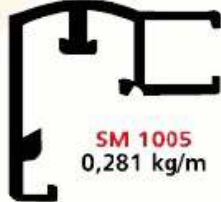

SM 1005
0,281 kg/m

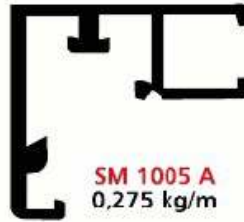

SM 1005 A
0,275 kg/m

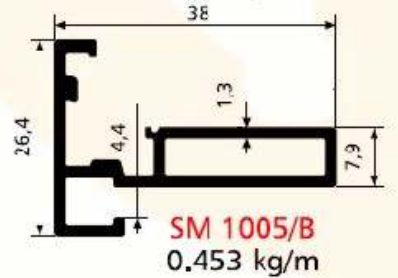

SM 1005/B
0,453 kg/m

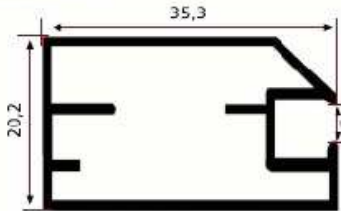

SM 1003 A
0,365 kg/m

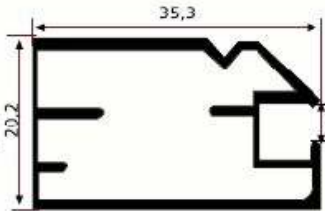

SM 1003 B
0,365 kg/m

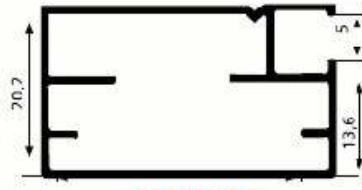

SM 1003 C
0,371 kg/m

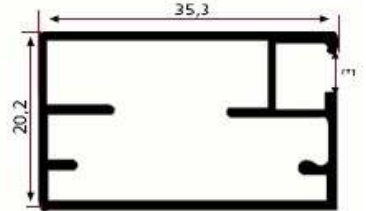

SM 1003 D
0,367 kg/m



SM-1016

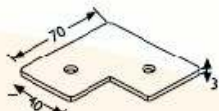

SM-1002



SM 1002 A

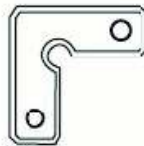

SM 1007 D

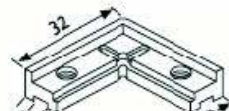

SM-1005

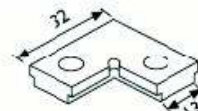

SM-1007

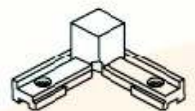

SM-1005

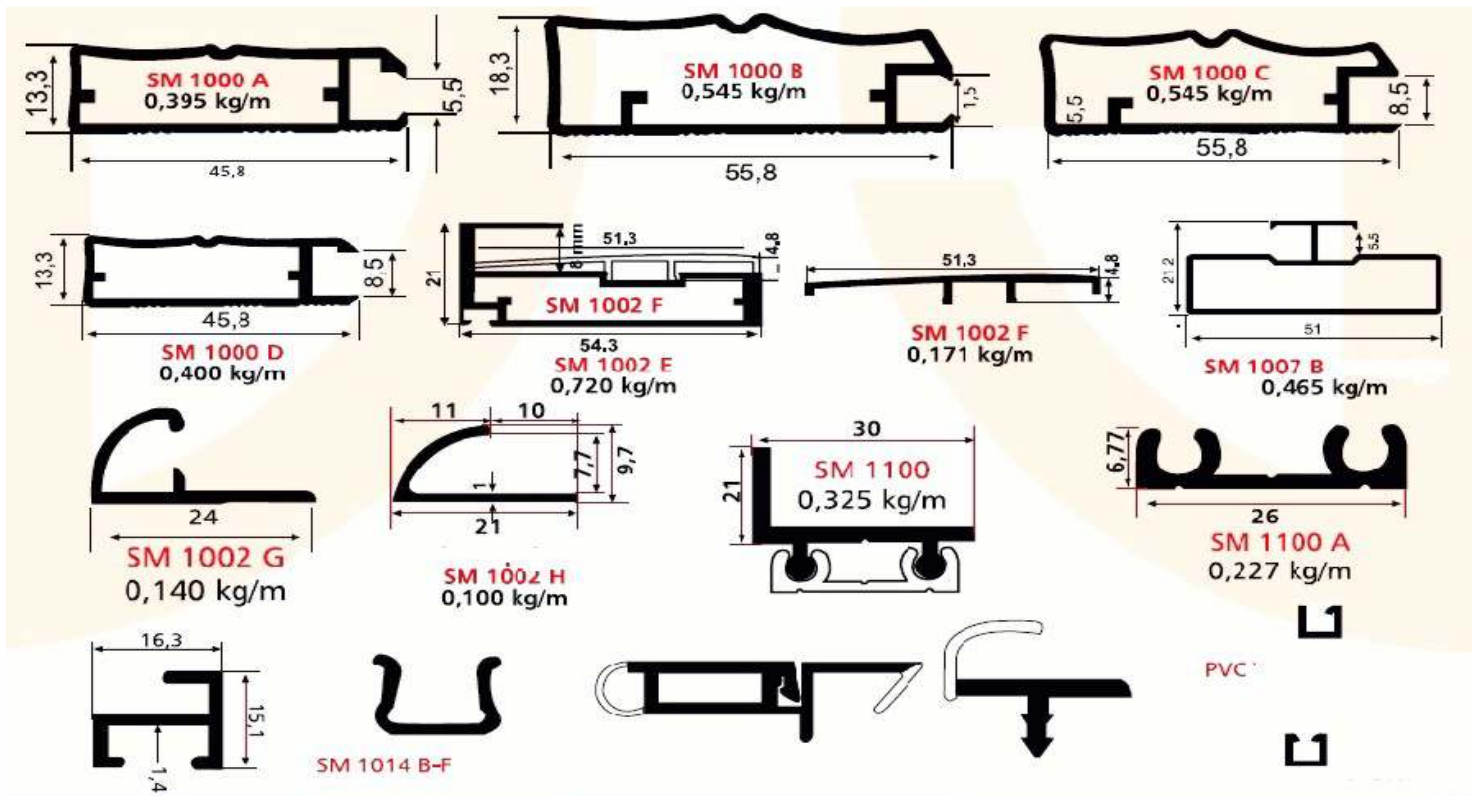
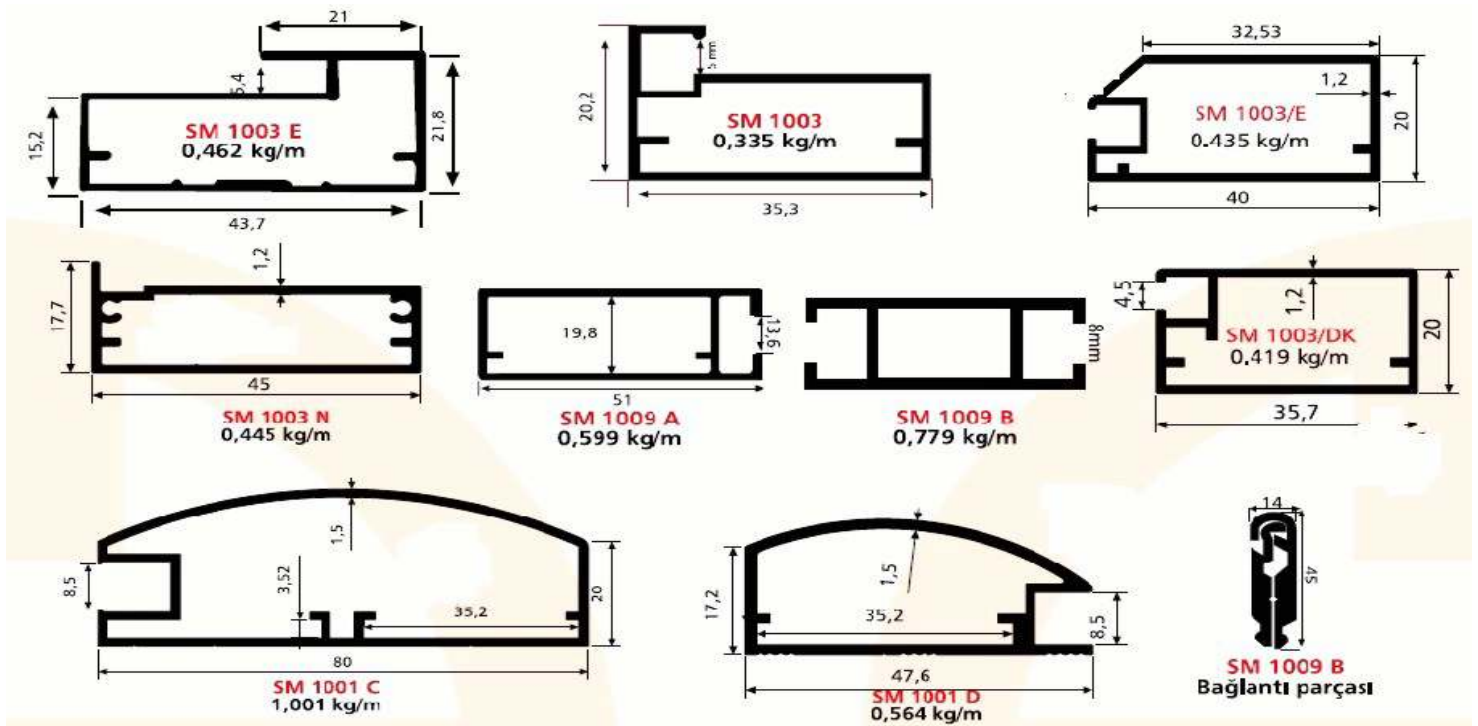

PROFILE si CANTURI pentru MOBILIER

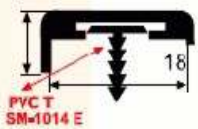

SM 1014 B
0,190 kg/m



SM 1014 F
0,170 kg/m

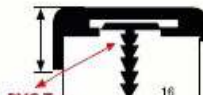

SM 1014 L
0,190 kg/m

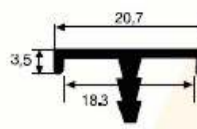

SM 1011 T
0,143 kg/m

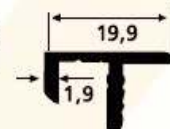

SM 1011 Z
0,170 kg/m

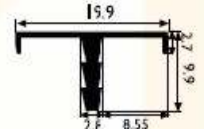

SM 1014 S
0,100 kg/m

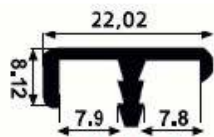

SM 1008 C
0,176 kg/m

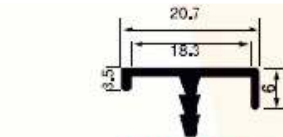

SM 1014 SK
0,143 kg/m

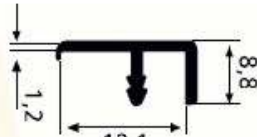

SM 1008 SD
0,115 kg/m

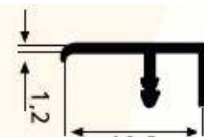

SM 1008 SE
0,125 kg/m

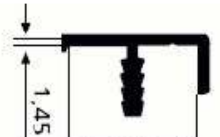

SM 1008 SF
0,175 kg/m

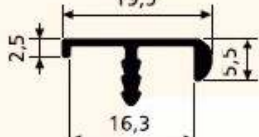

SM 1008/D
0,119 kg/m

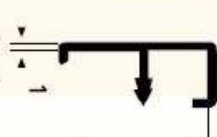

SM 1008 SG
0,115 kg/m

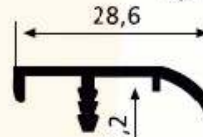

SM 1008 SH
0,175 kg/m

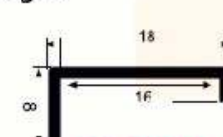

SM 1008 A
0,080 kg/m

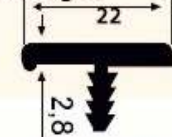

SM 1011 V
0,227 kg/m

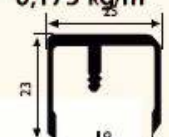

SM 1014 M
0,360 kg/m

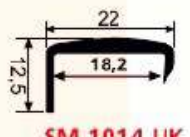

SM 1014 UK
0,190 kg/m

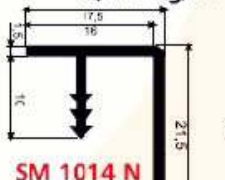

SM 1014 N
0,192 kg/m

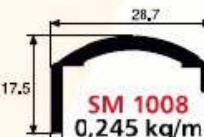

SM 1008
0,245 kg/m

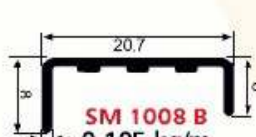

SM 1008 B
0,105 kg/m

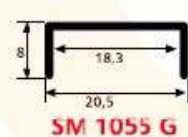

SM 1055 G
0,101 kg/m

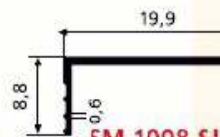

SM 1008 SJ
0,088 kg/m

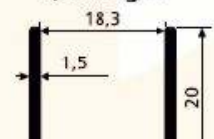

SM 1055/M
0,053 kg/m

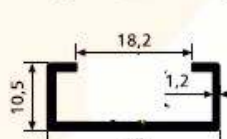

SM 1055/N
0,177 kg/m

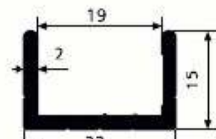

SM 1055/U
0,273 kg/m

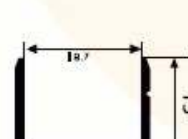

SM 1055 B
0,159 kg/m

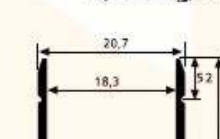

SM 1055 H
0,151 kg/m

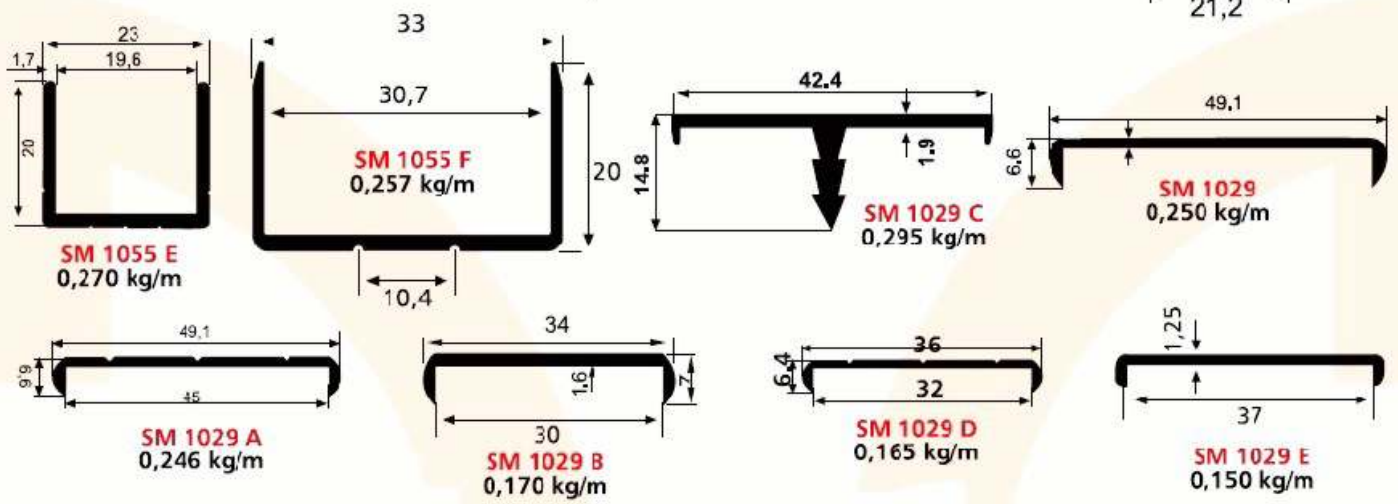
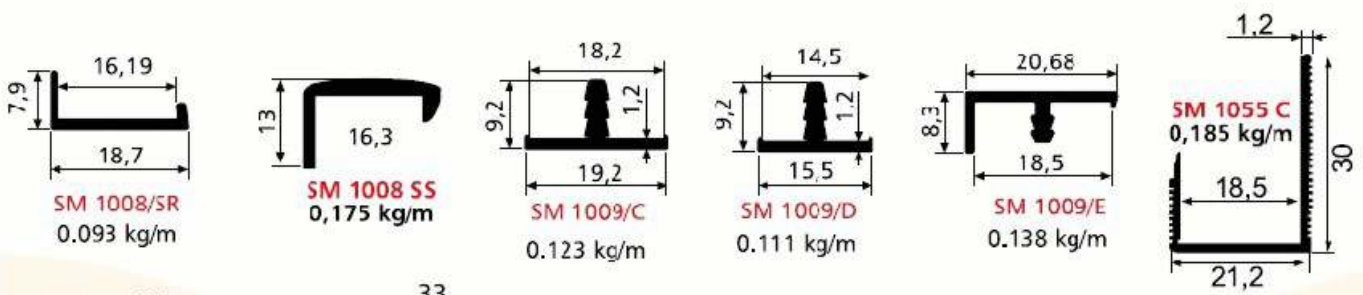
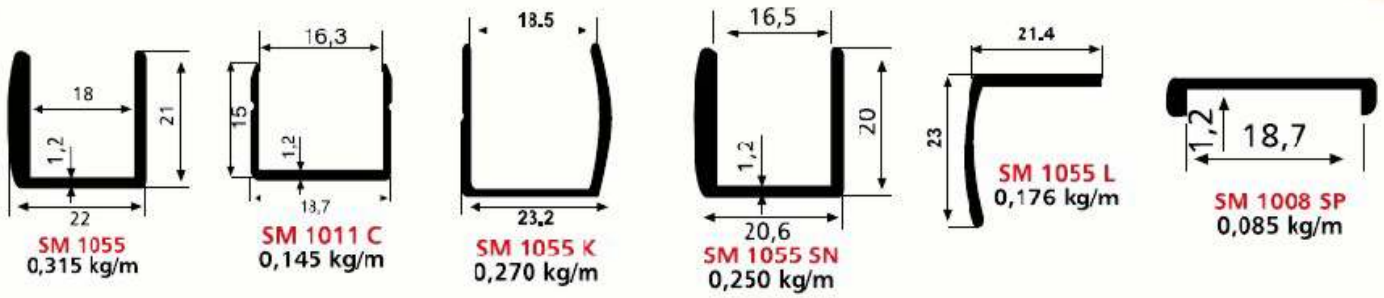

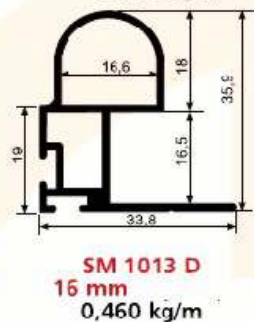
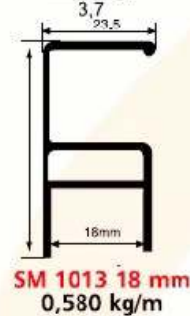
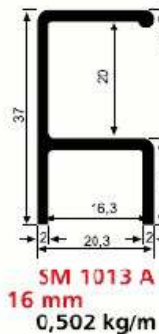
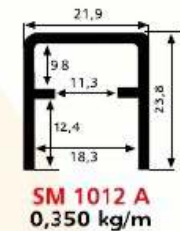
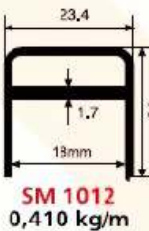
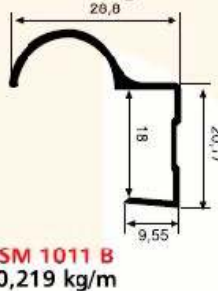
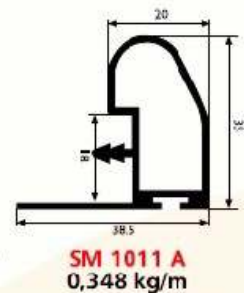
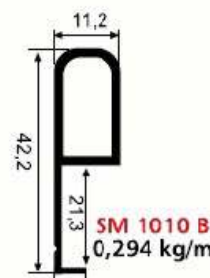
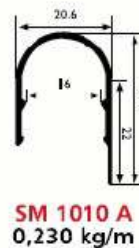
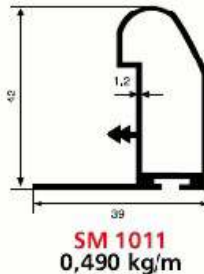
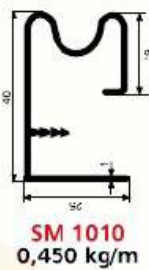
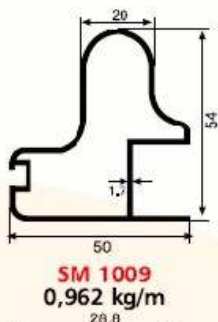
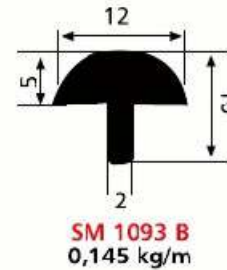
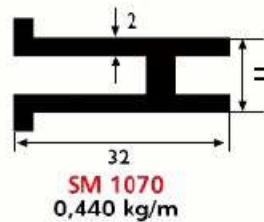
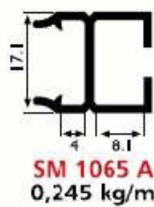
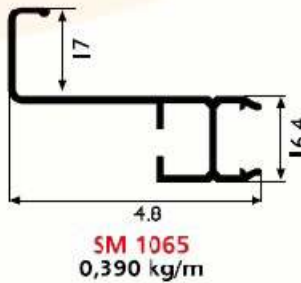
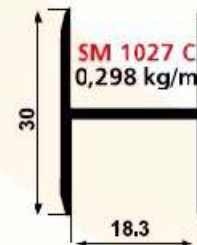
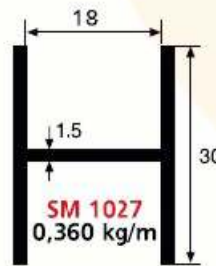
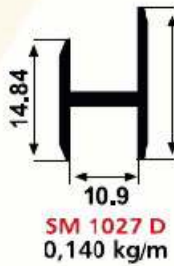
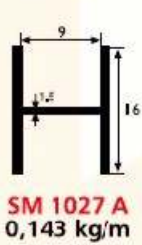
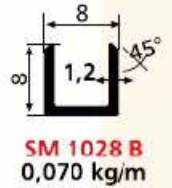
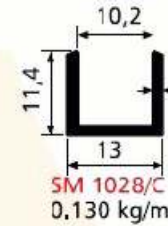
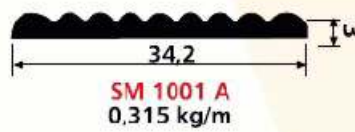
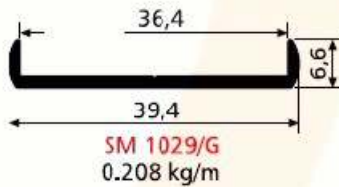
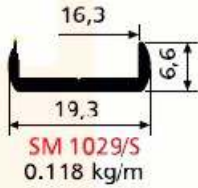
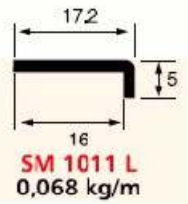
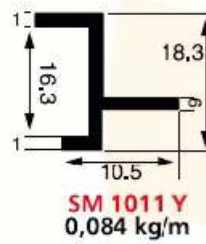
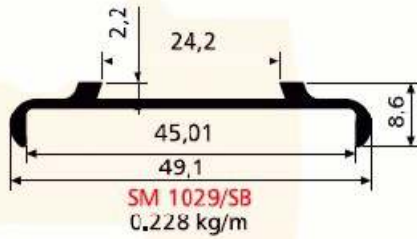
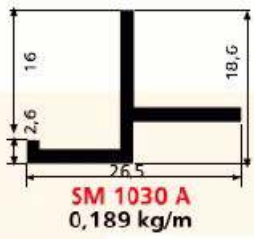

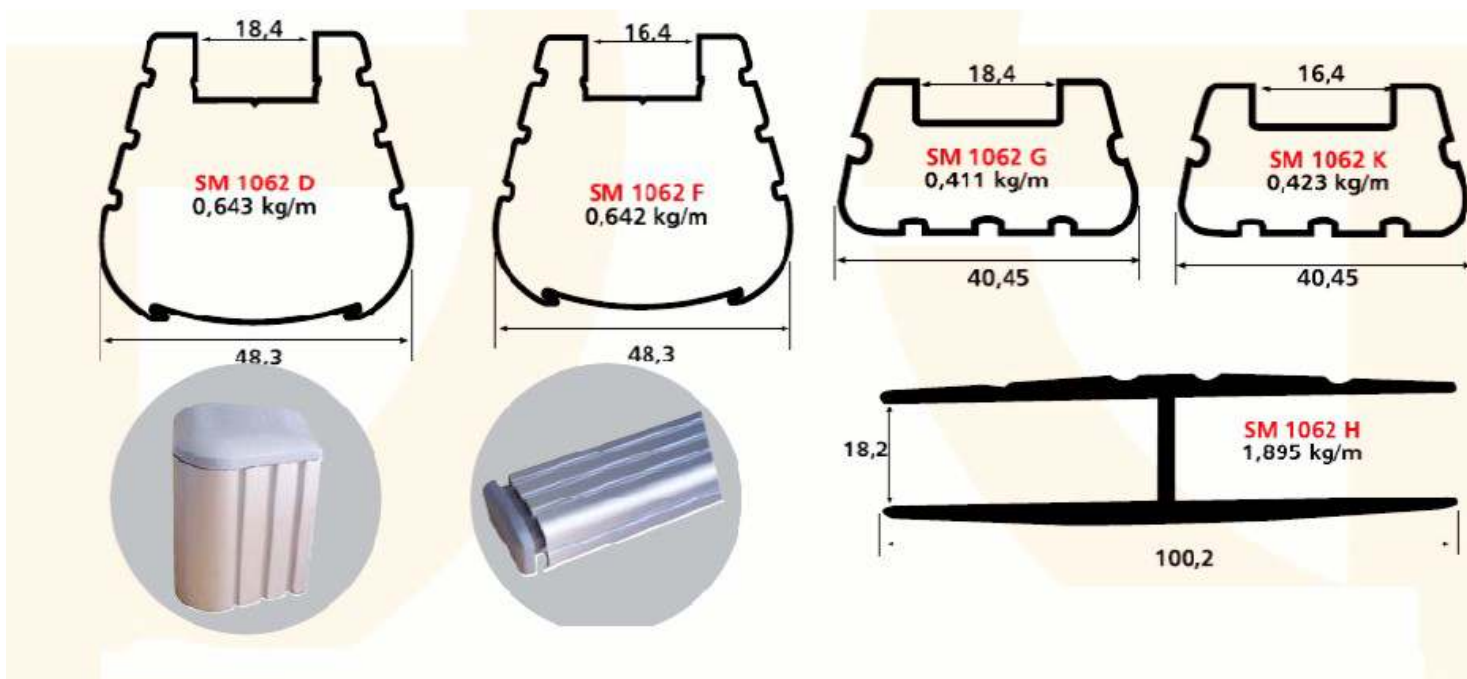
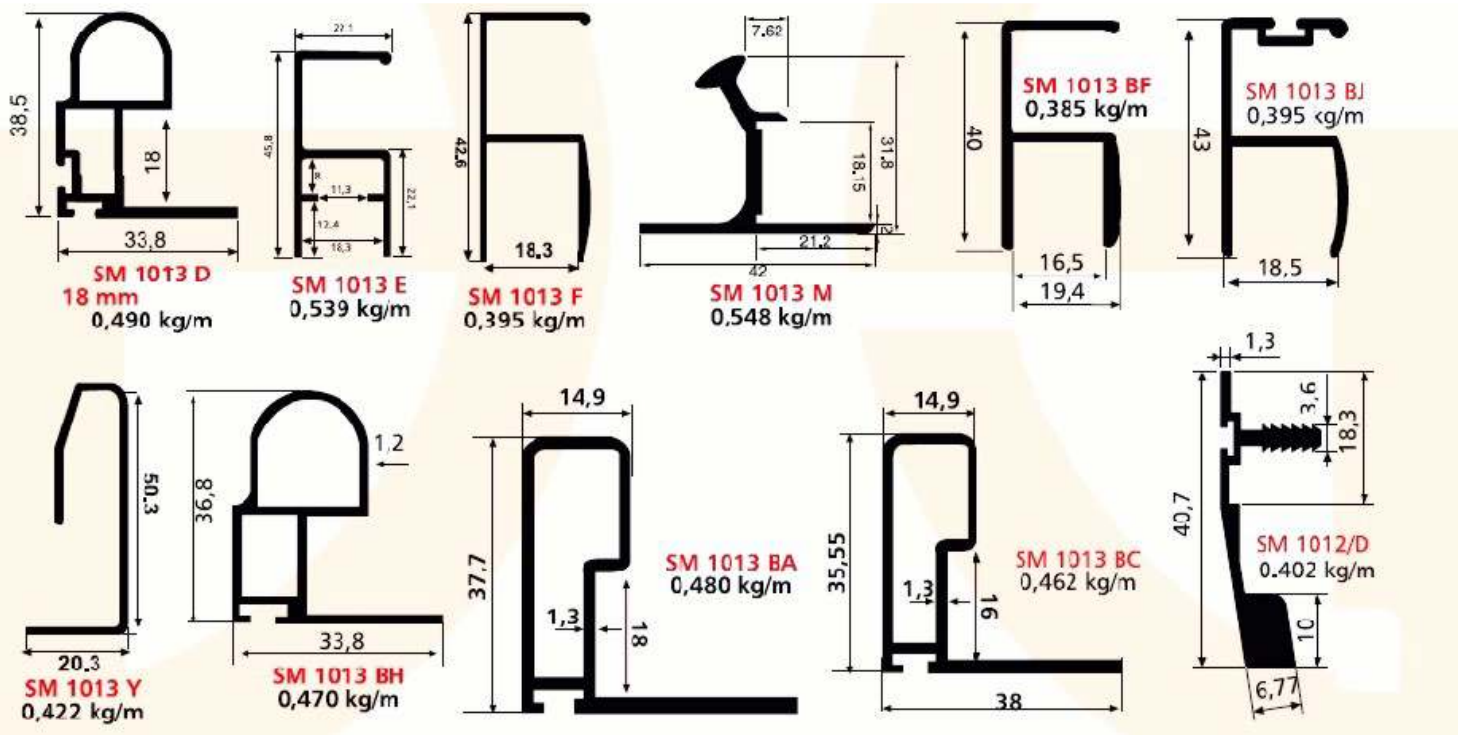

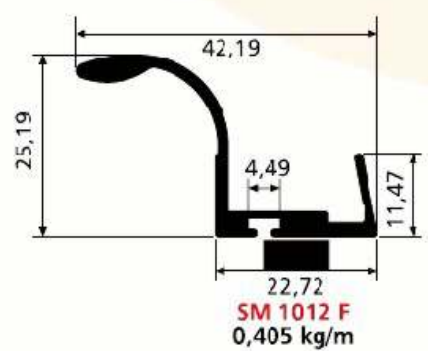
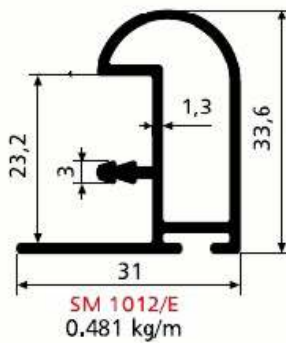
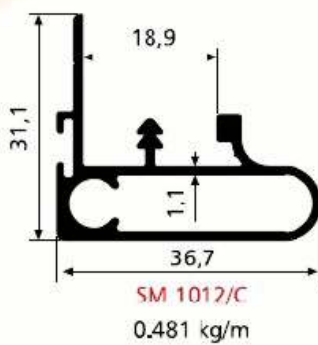
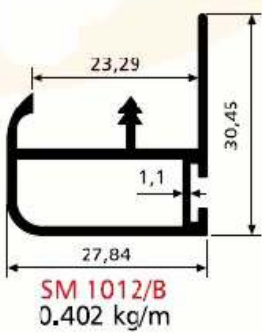
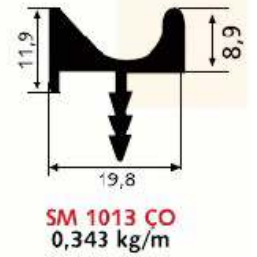
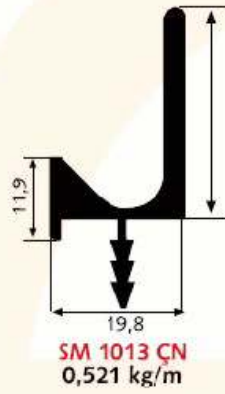
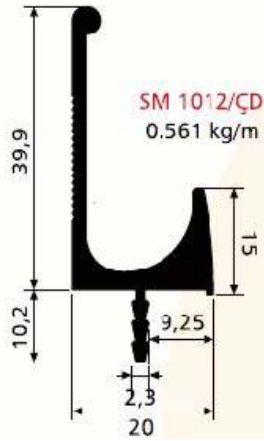
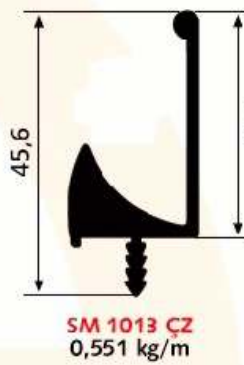
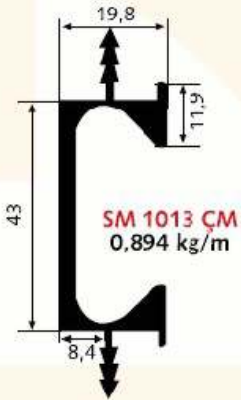
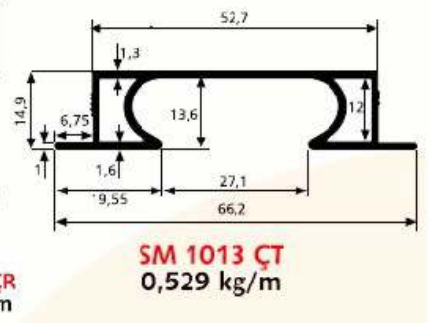
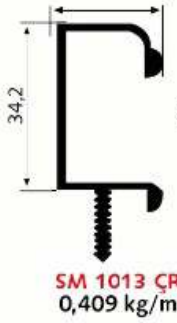
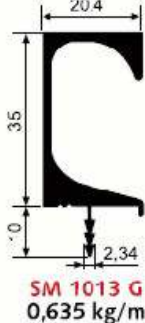
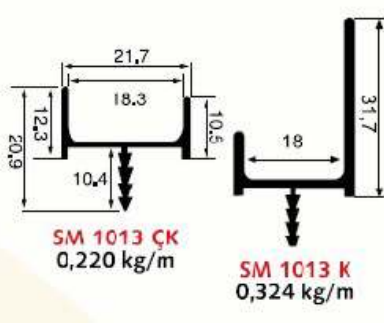
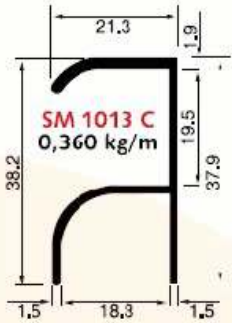

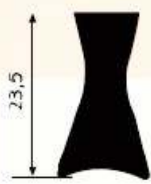

SM 6013 E
0,520 kg/m

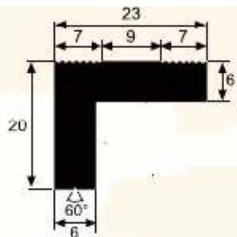

SM 6013 M
0,594 kg/m

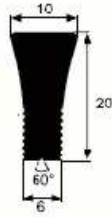

SM 6013 K
0,373 kg/m



SM 1013 L
0,383 kg/m



SM 1013 CS
0,276 kg/m



SM 6013 A
0,617 kg/m



SM 6013 B
0,667 kg/m

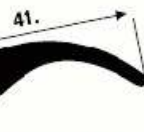

SM 6013 C
0,643 kg/m

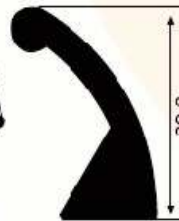

SM 6013 F
0,605 kg/m

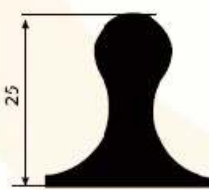

SM 6013 G
0,700 kg/m

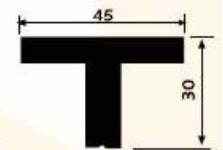

SM 6013 H
1,580 kg/m

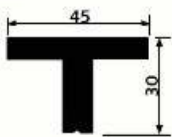

SM 6013 I
1,460 kg/m

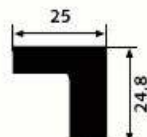

SM 6013 Ĩ
0,950 kg/m

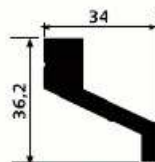

SM 6013 J
0,980 kg/m

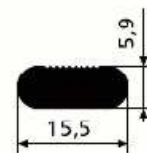

SM 6014
0,236 kg/m

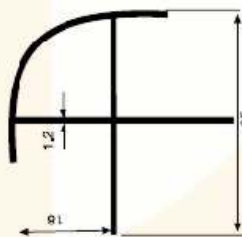
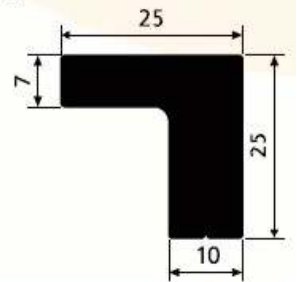

SM 1052
0,485 kg/m

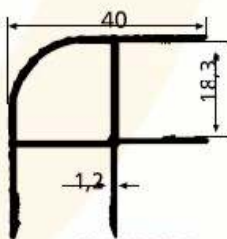

SM 1052 E
0,510 kg/m

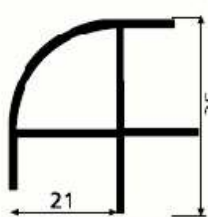

SM 1052 F
0,385 kg/m

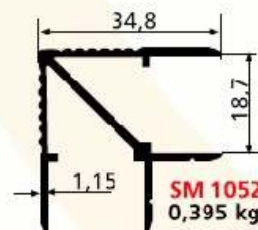

SM 1052 G
0,395 kg/m

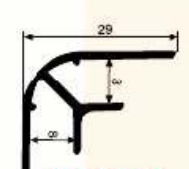

SM 1014 K
0,255 kg/m

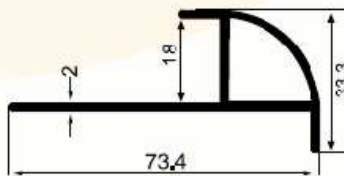

SM 1052 A
0,788 kg/m

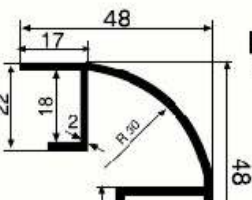

SM 1051
0,735 kg/m

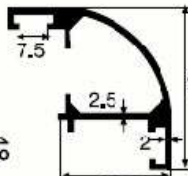

SM 1050
0,860 kg/m

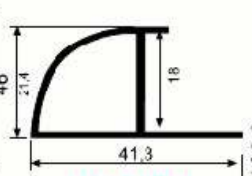

SM 1052 B
0,320 kg/m

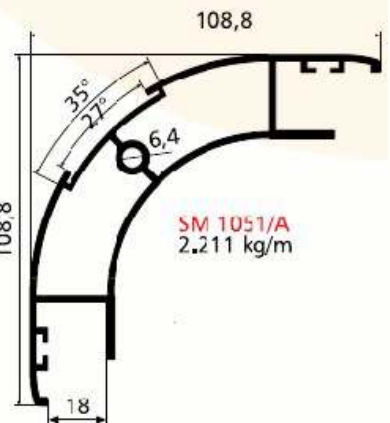

SM 1051/A
2,211 kg/m

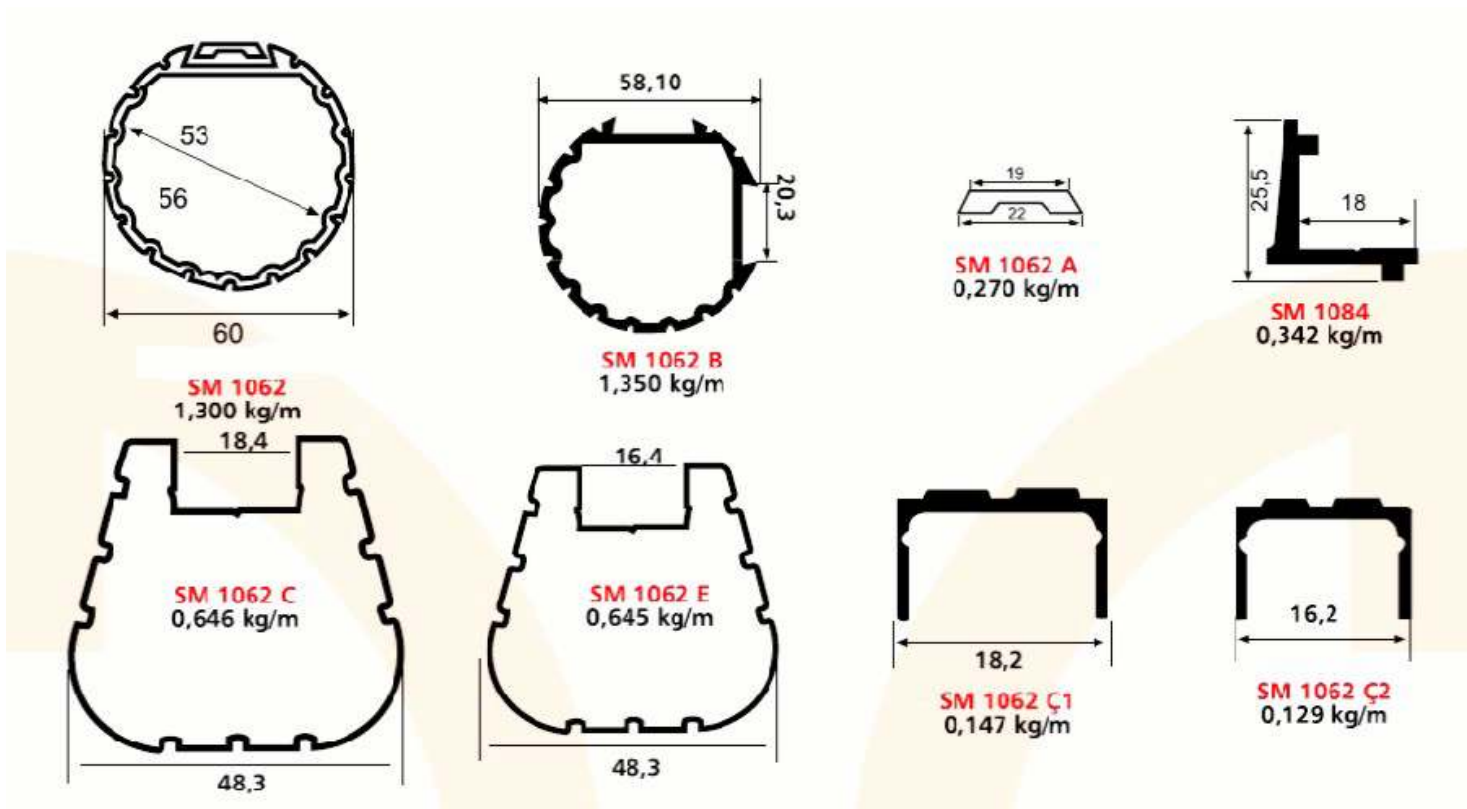

USI GLISANTE si accesorii...



09 - SKS 51



10 - MKX 2B



11 - 05 MKK 2



12 - SKS 99C



13 - SGM 01
13 - SGM 01



14 - SGM 02
14 - SGM 02



15



16 -

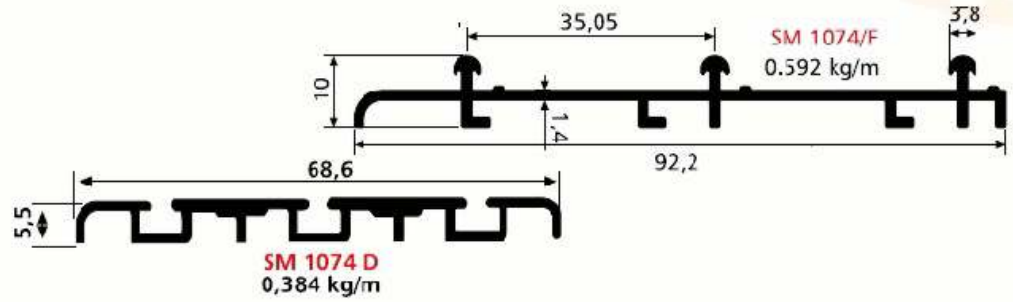
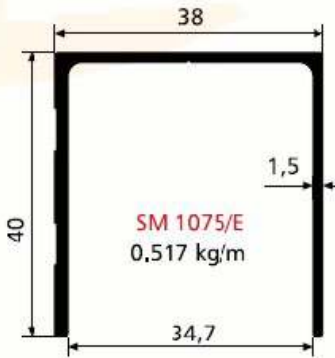
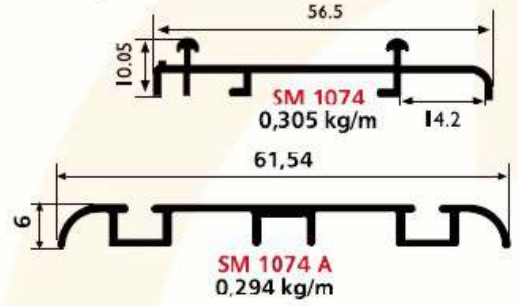
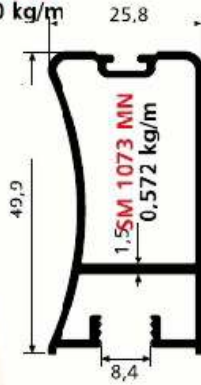
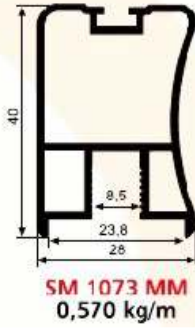
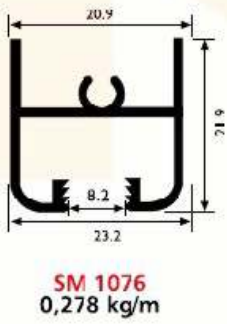
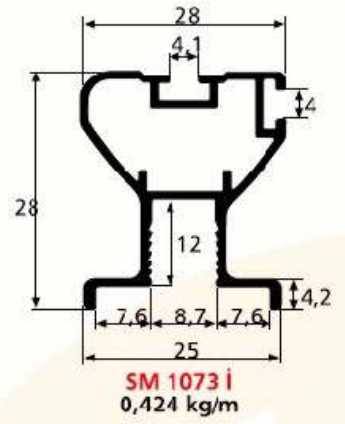
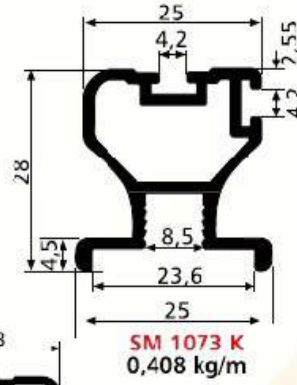
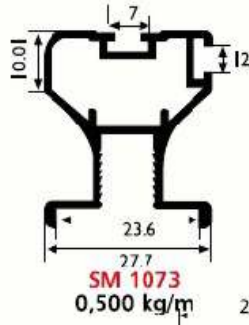
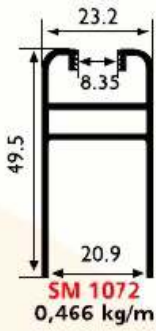
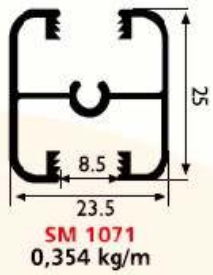

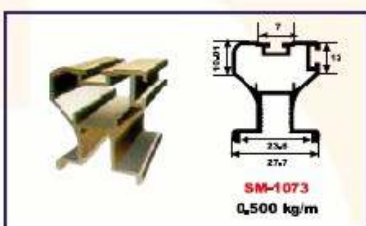
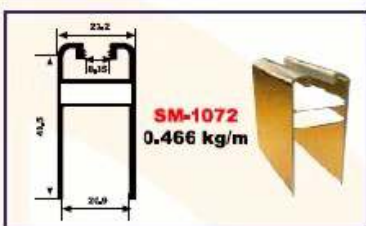
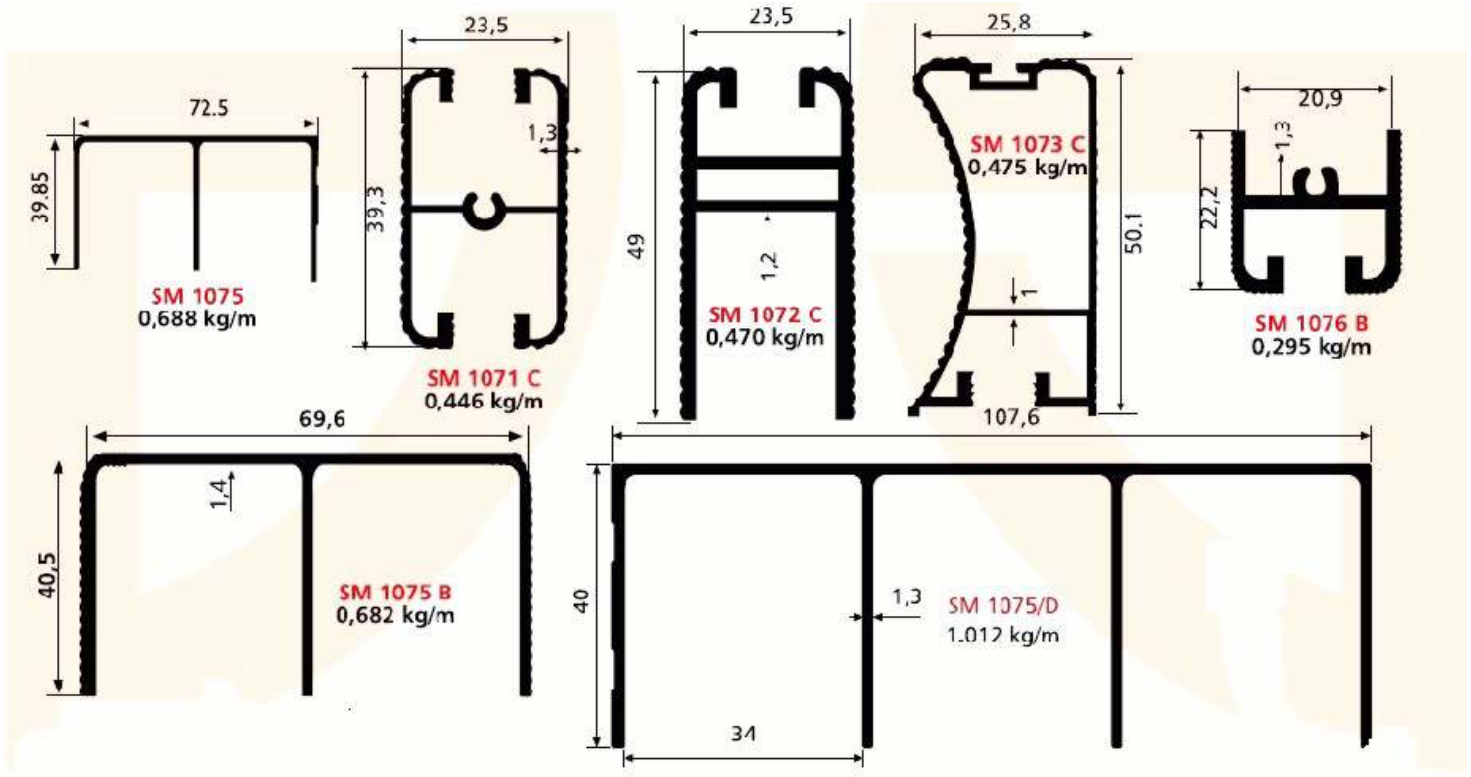

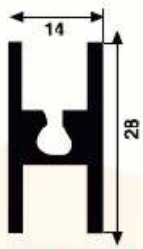

SM 1071 A
0,434 kg/m

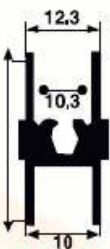

SM 1071 B
0,340 kg/m

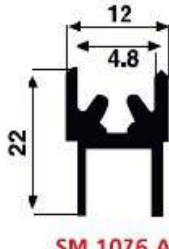

SM 1076 A
0,292 kg/m

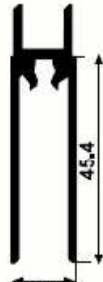

SM 1072 A
0,528 kg/m

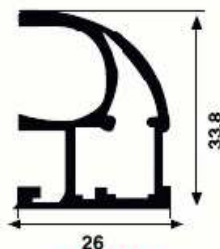

SM 1073 A
0,495 kg/m

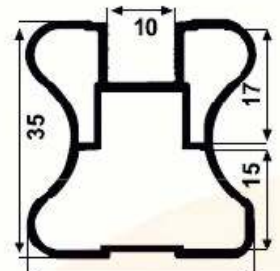

SM 1073 B
0,501 kg/m

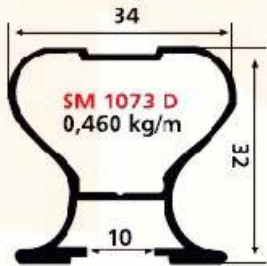

SM 1073 D
0,460 kg/m

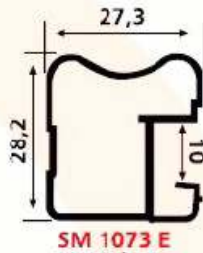

SM 1073 E
0,365 kg/m

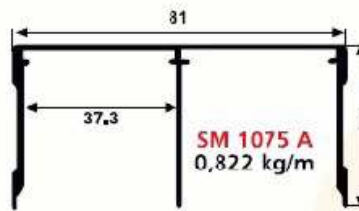

SM 1075 A
0,822 kg/m

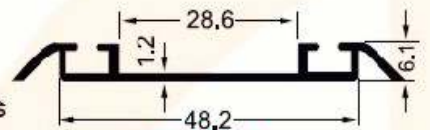

SM 1074 B
0,300 kg/m



SM-1075
0,666 kg/m

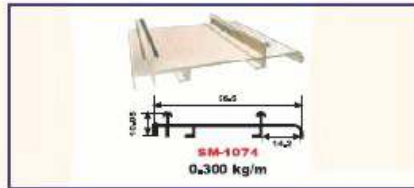

SM-1074
0,300 kg/m

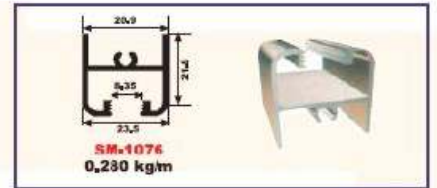

SM-1076
0,280 kg/m

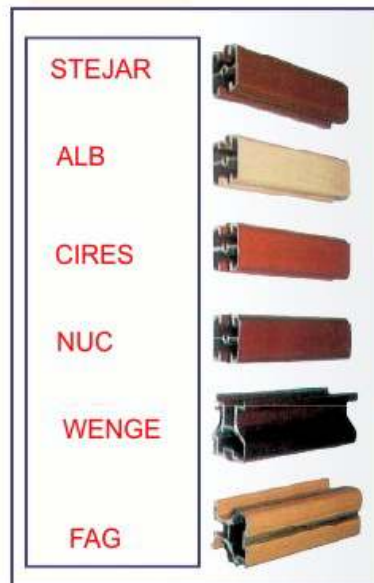

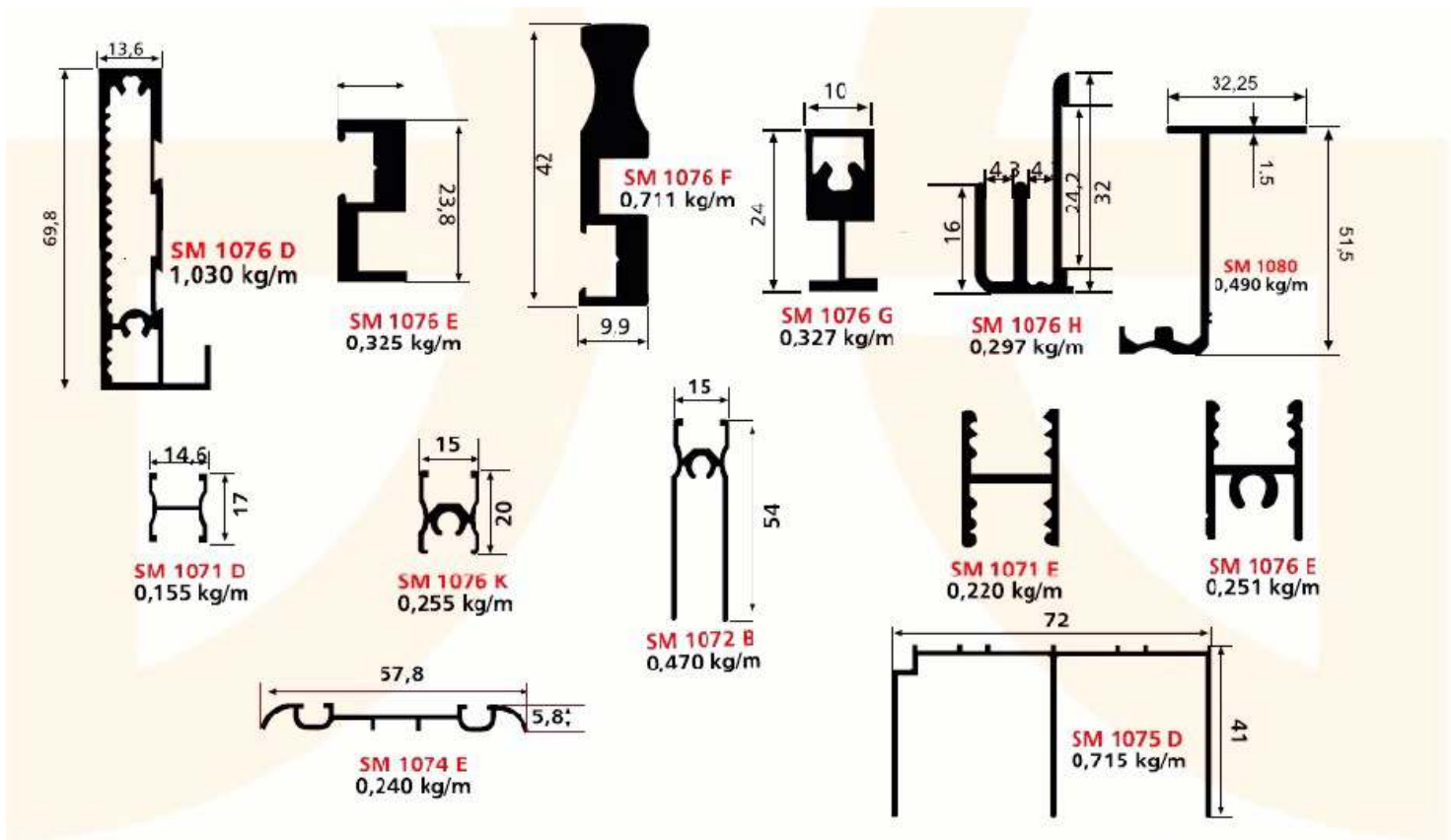

SM 1074 A



SM 1074 A



SM 1073 A

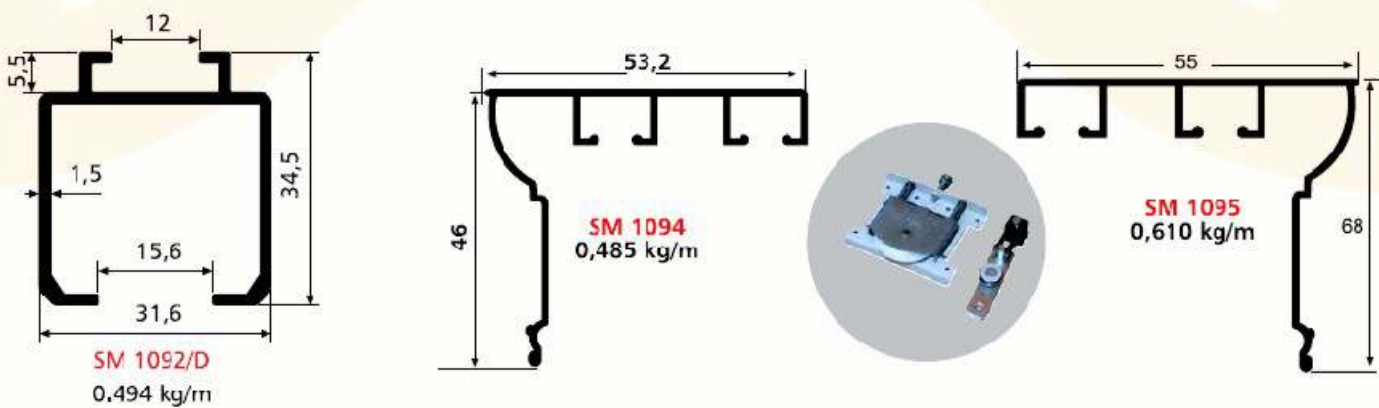
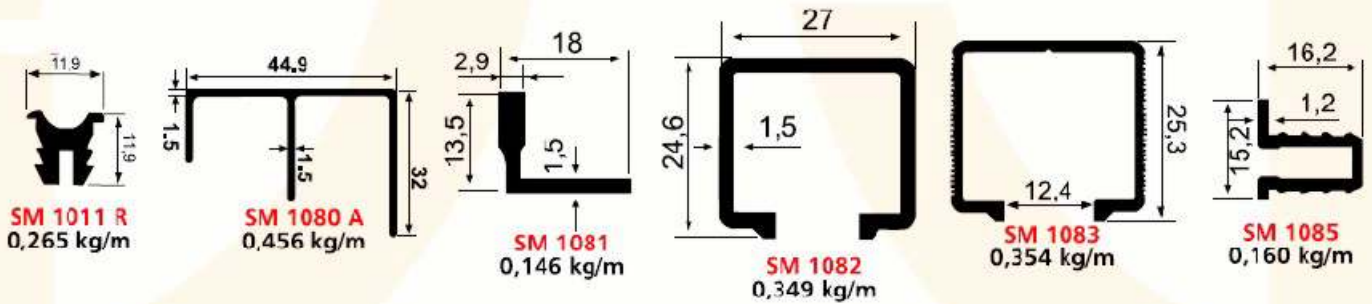
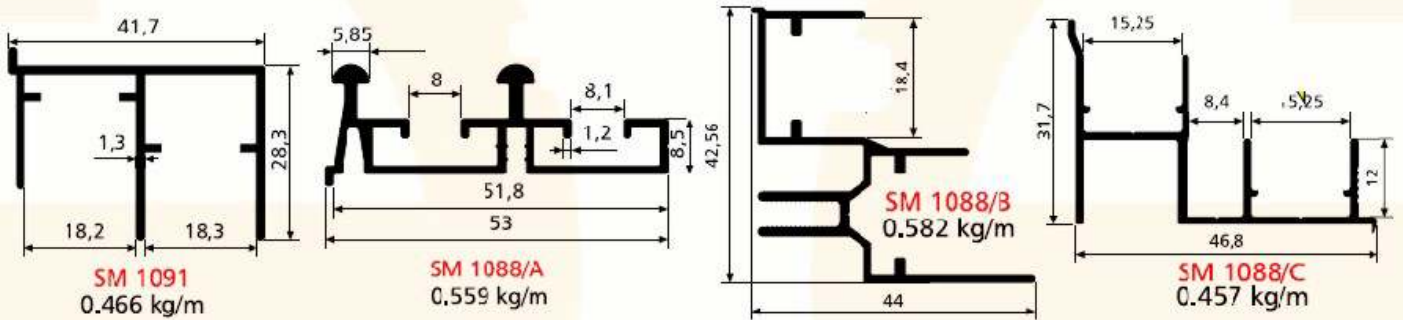
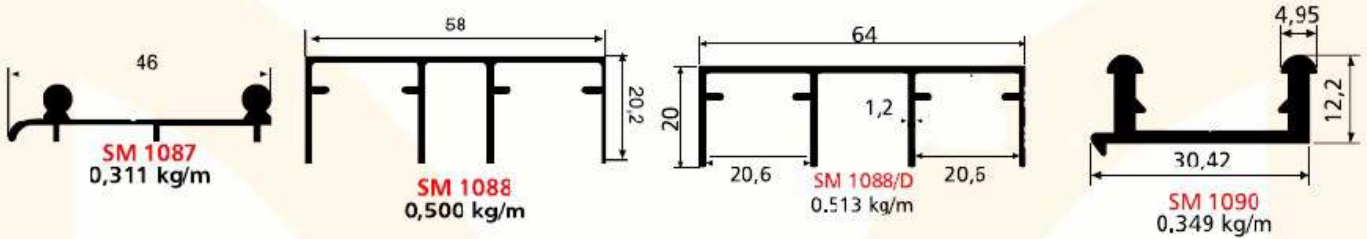
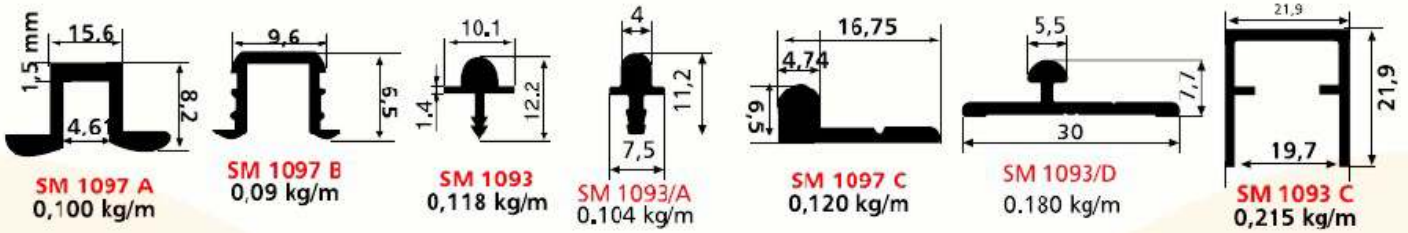

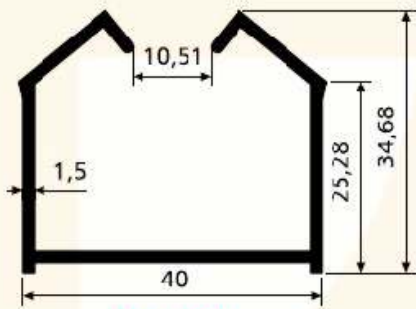

SM 1082/A
0.542 kg/m

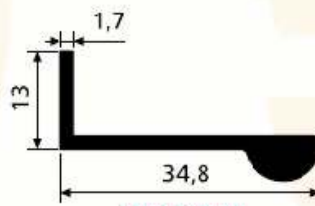

SM 1082/B
0.315 kg/m

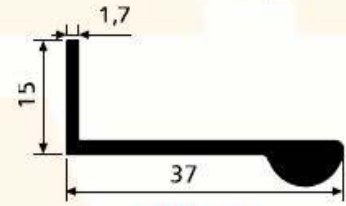

SM 1082/C
0.335 kg/m

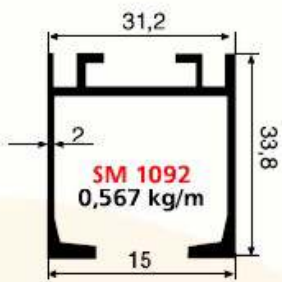

SM 1092
0.567 kg/m

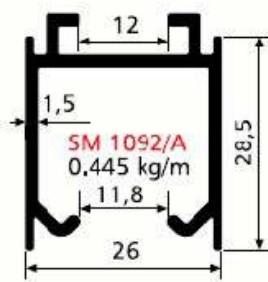

SM 1092/A
0.445 kg/m

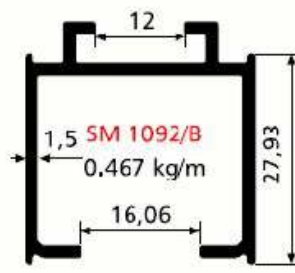

SM 1092/B
0.467 kg/m

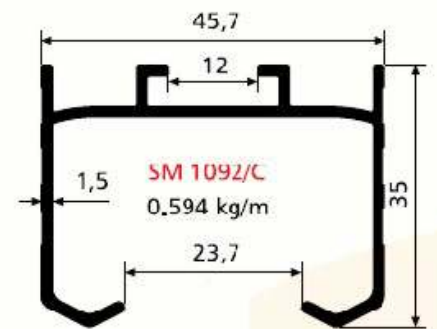

SM 1092/C
0.594 kg/m

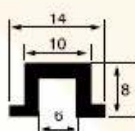

SM 1097
0.140 kg/m

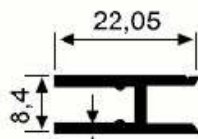

SM 1086
0.152 kg/m

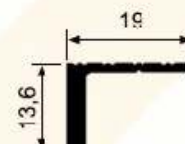

SM 1089
0.354 kg/m



01 - SKM 30



02 - SKM 60



03 - SKM 60 AY



04 - SKM 75 AY



05 - SKM 28 Y



06 - SKM 38 Y



07 - SKM 80



08 - SKM 80 AY

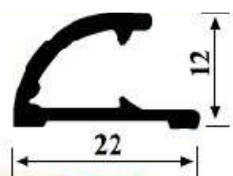

ST 203
0.170 kg/m

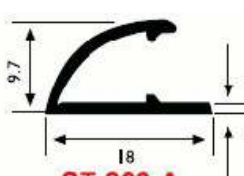

ST 203 A
0.110 kg/m

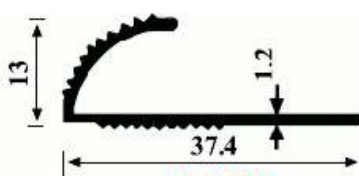

ST 204
0.180 kg/m

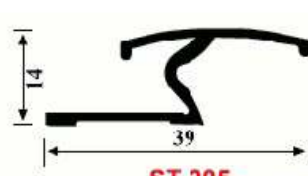

ST 205
0.270 kg/m

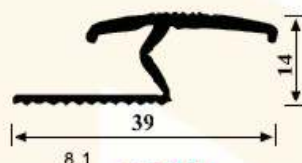

ST 206
0.240 kg/m

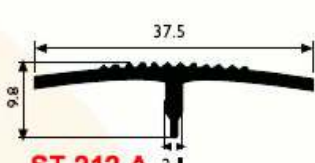

ST 212 A
0.175 kg/m



ST 212
0.210 kg/m



ST 213
0.350 kg/m

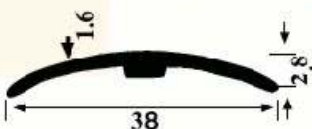

ST 216
0.290 kg/m



ST 216 A
0.190 kg/m

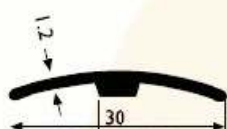

ST 216 B
0.124 kg/m

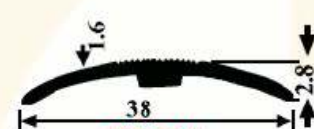

ST 217
0.180 kg/m



ST 227
0.185 kg/m



ST 227 A
0.190 kg/m

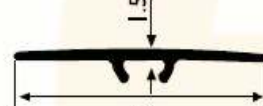

ST 227 B
0.130 kg/m



ST 239
0.170 kg/m

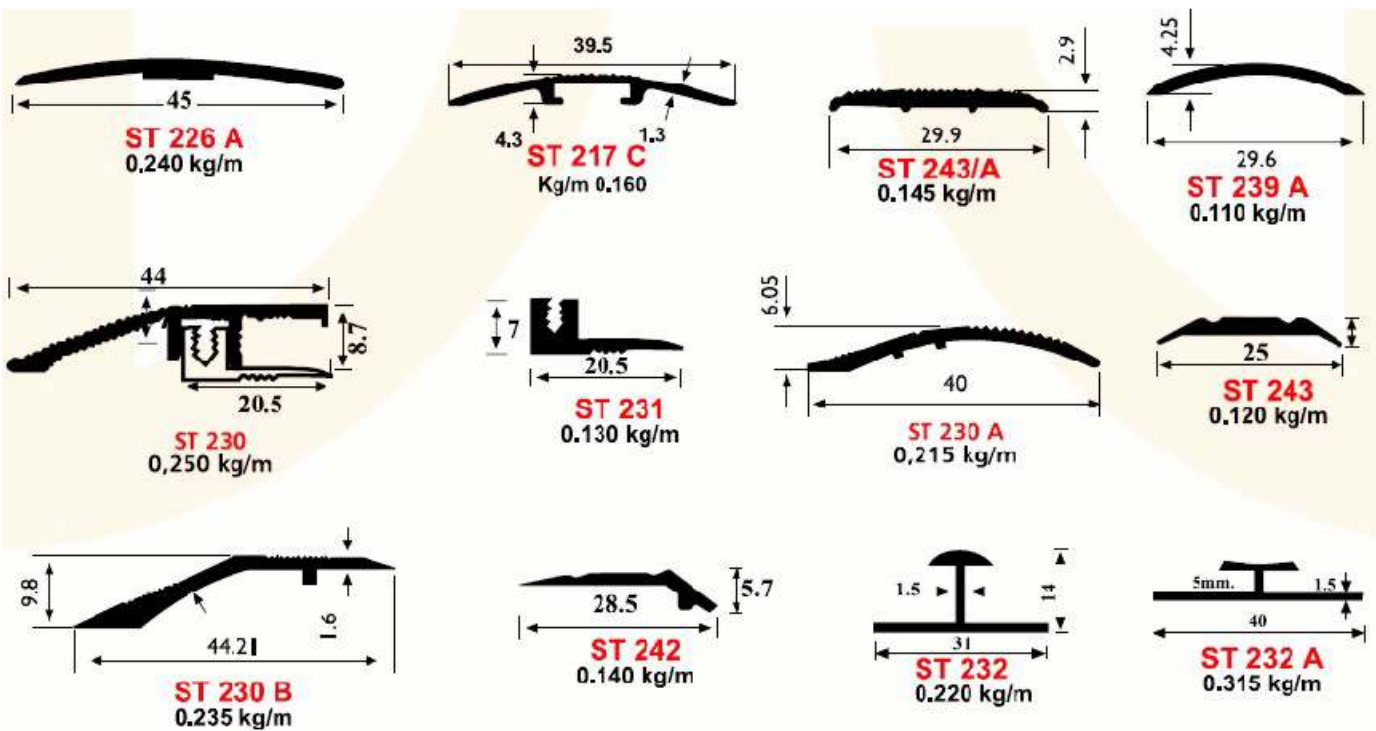
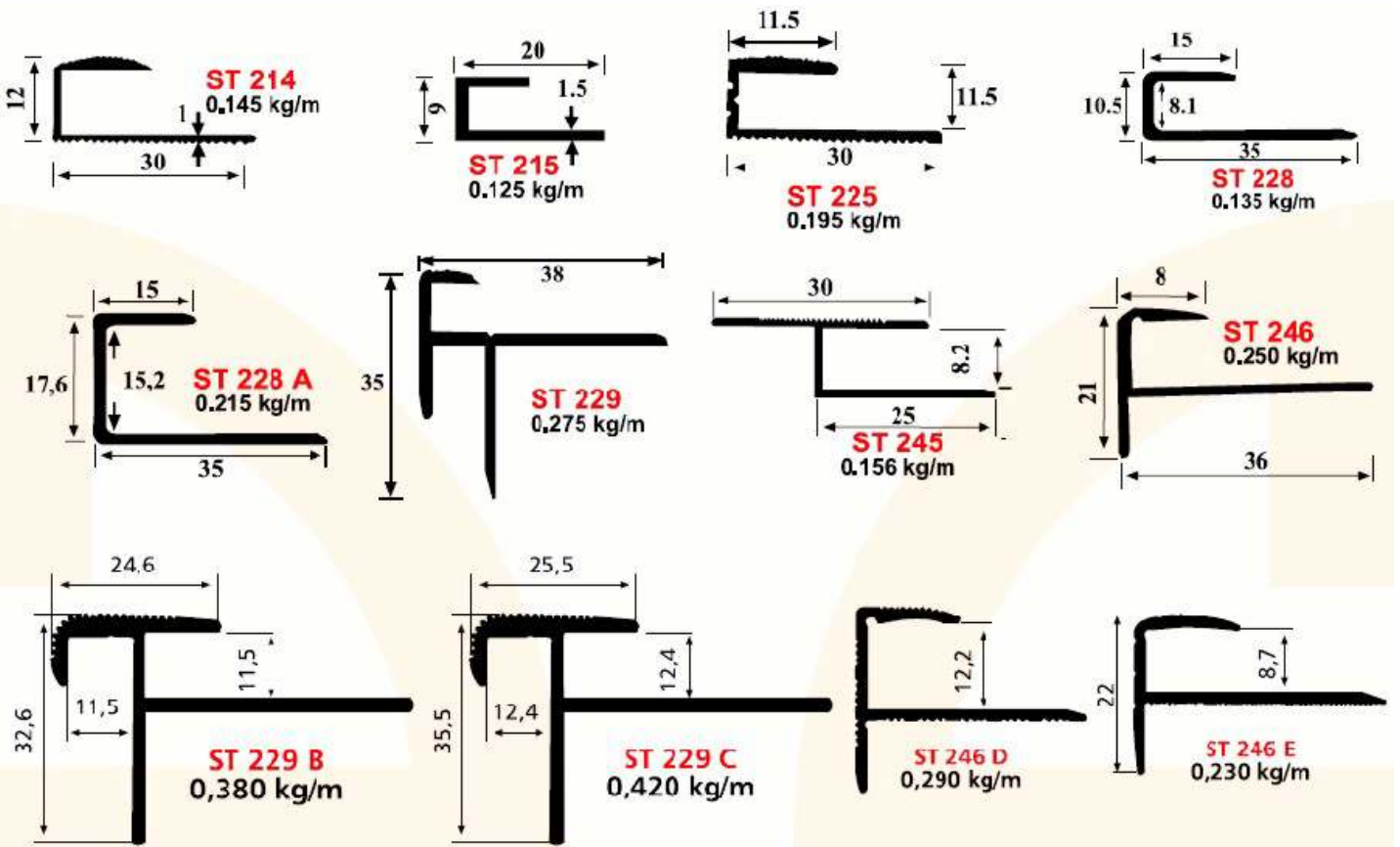

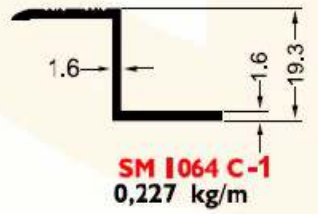
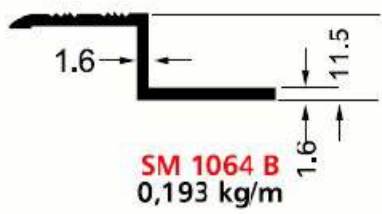
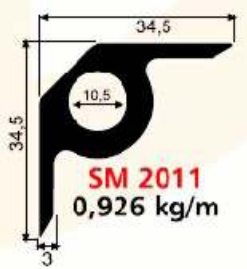
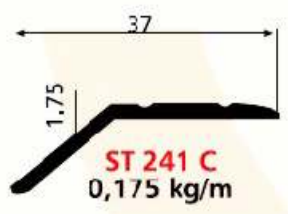
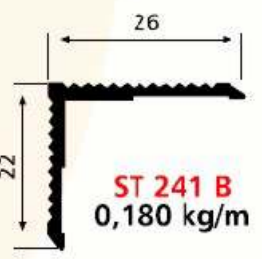
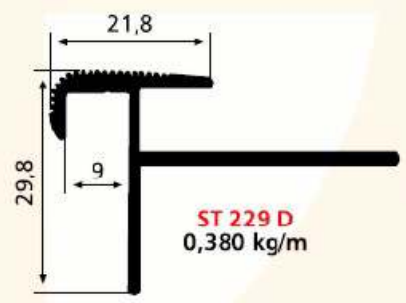
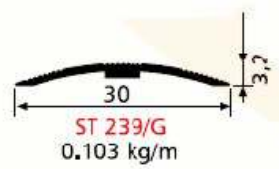
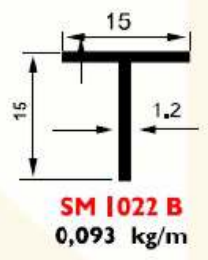
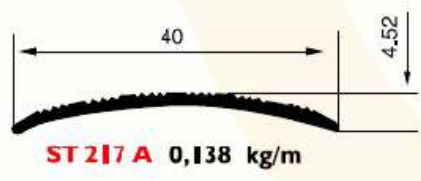
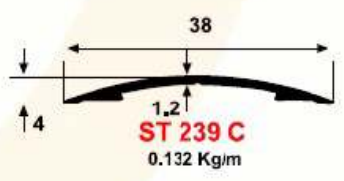
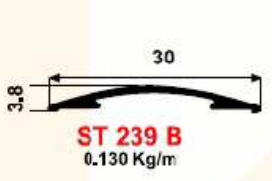
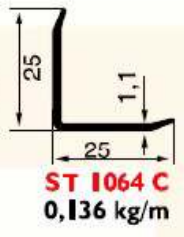
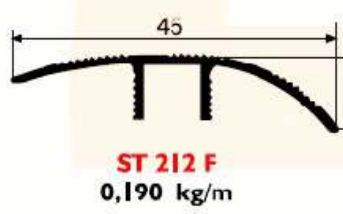
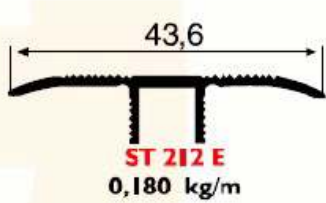
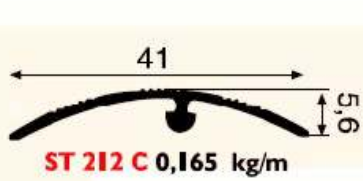

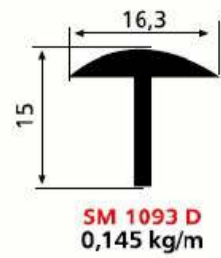
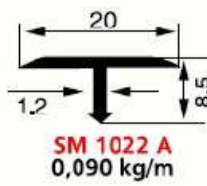
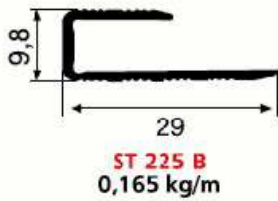
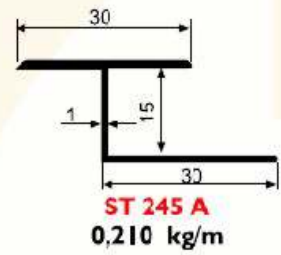
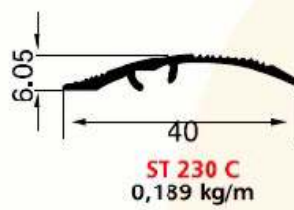
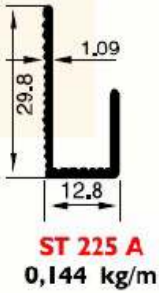
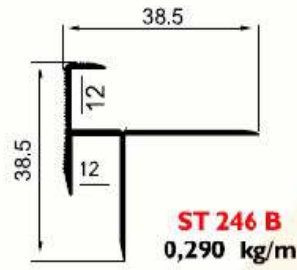
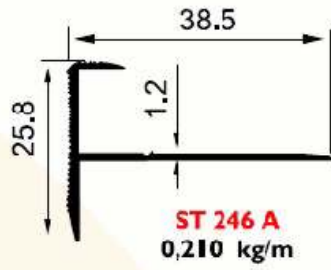
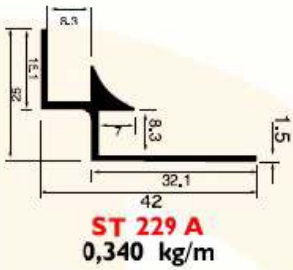
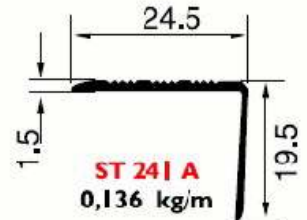
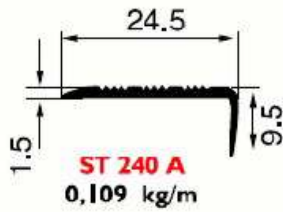
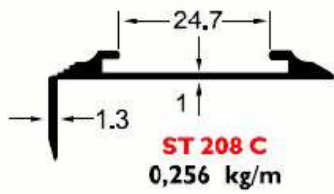
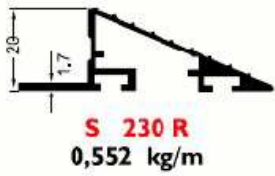

PROFILE PROTECTIE TREPTE

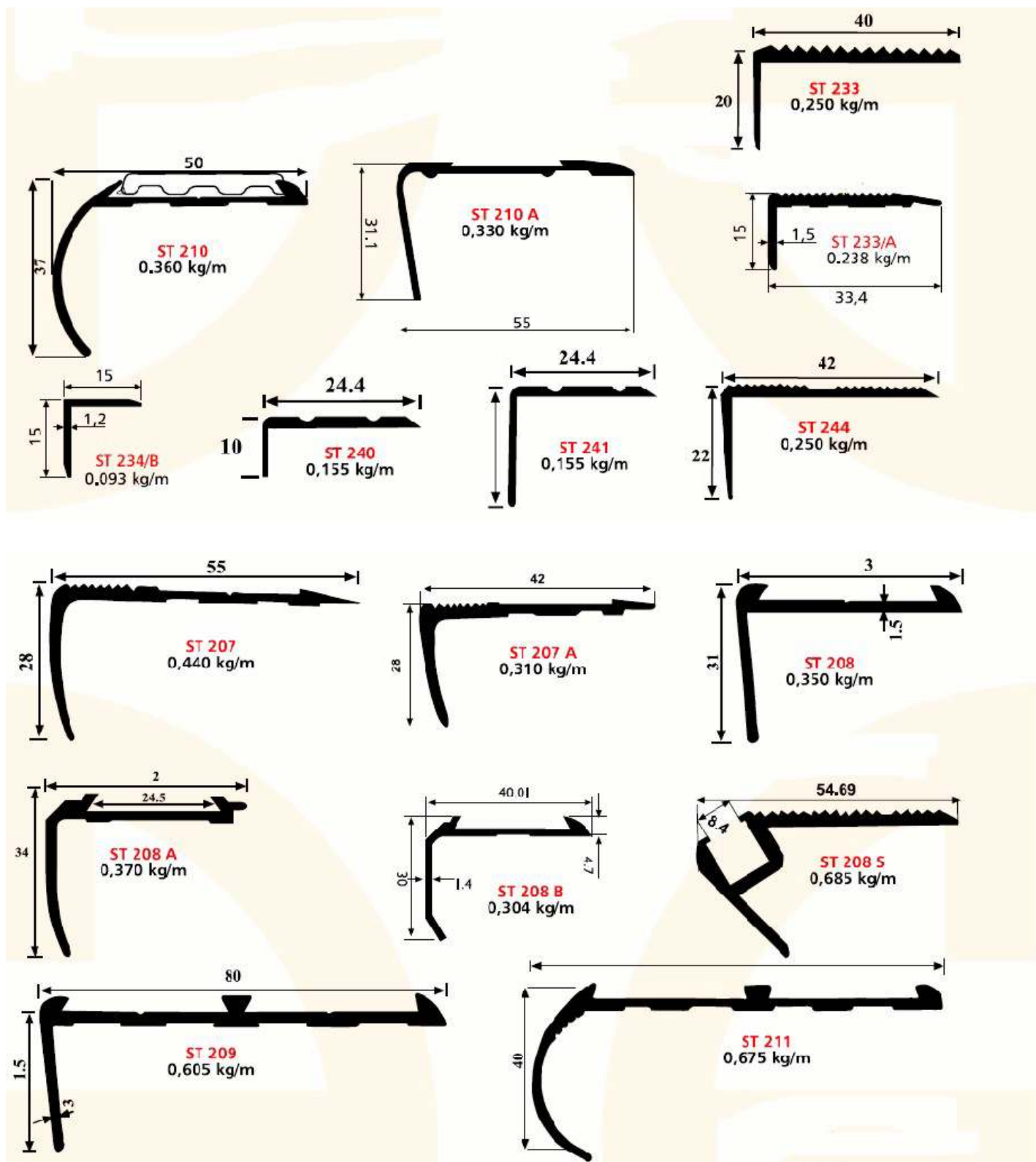

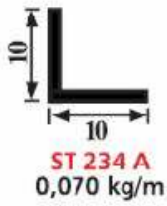
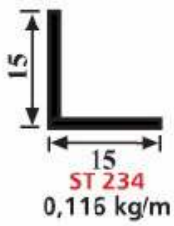

CORNIERE

ST 235 20x20 L **ST 236** 25x25 L **ST 237** 20x40 L **ST 238** 20x60 L

GARNITURA PROTECTIE



PROFILI ACOPERIRI CERAMICE

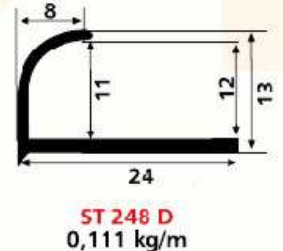
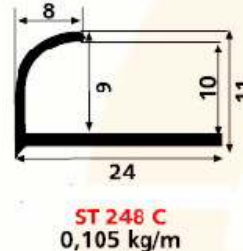
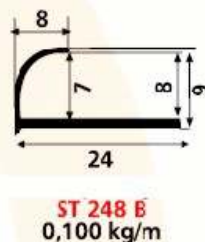
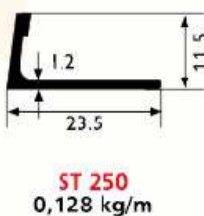
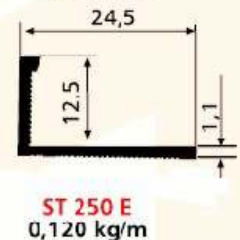
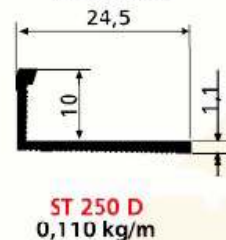
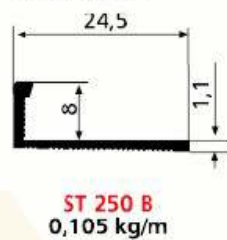
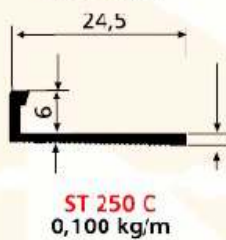
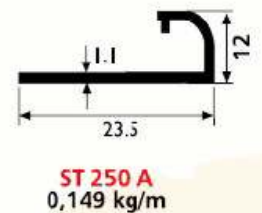
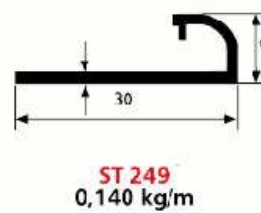
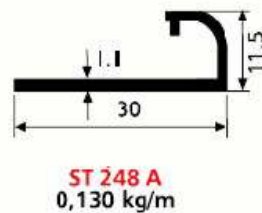
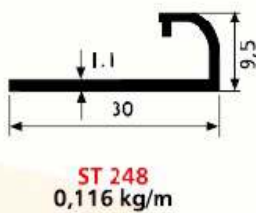
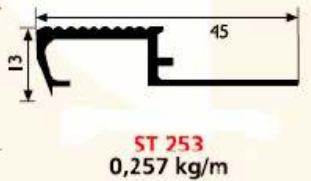
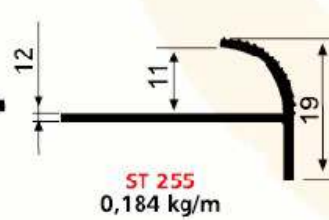
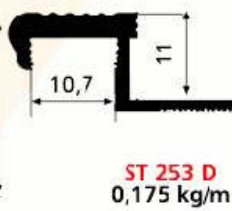
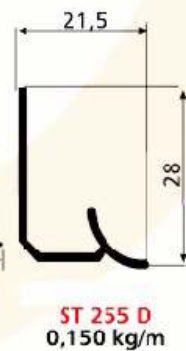
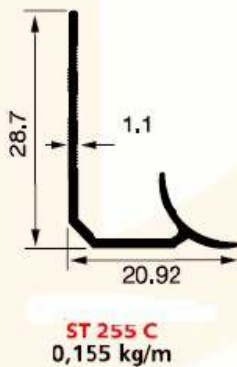
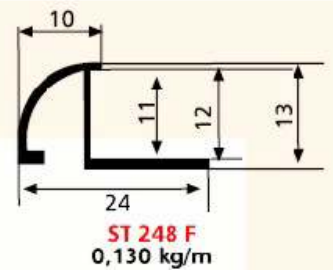
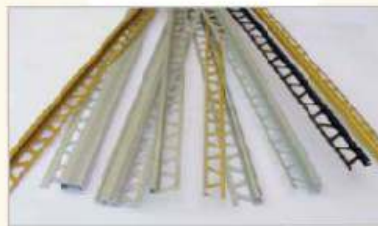
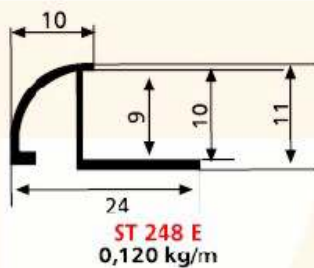

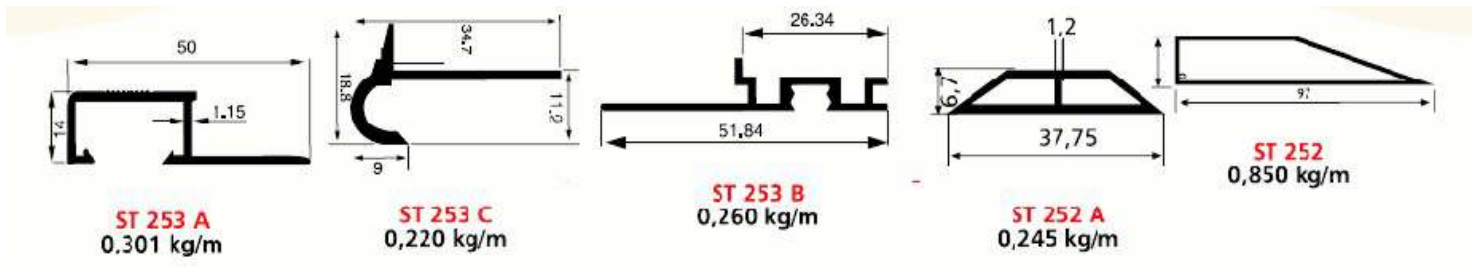

PROFILE pentru BLATURI si PLIANTE PARDOSELI

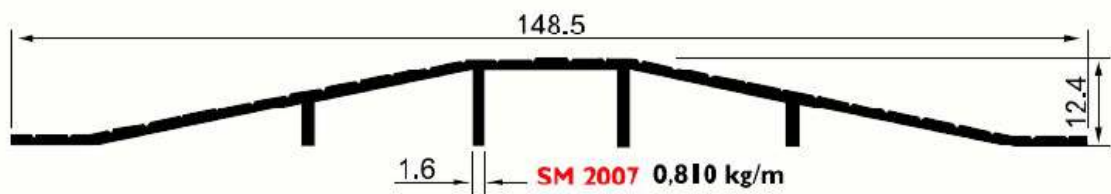
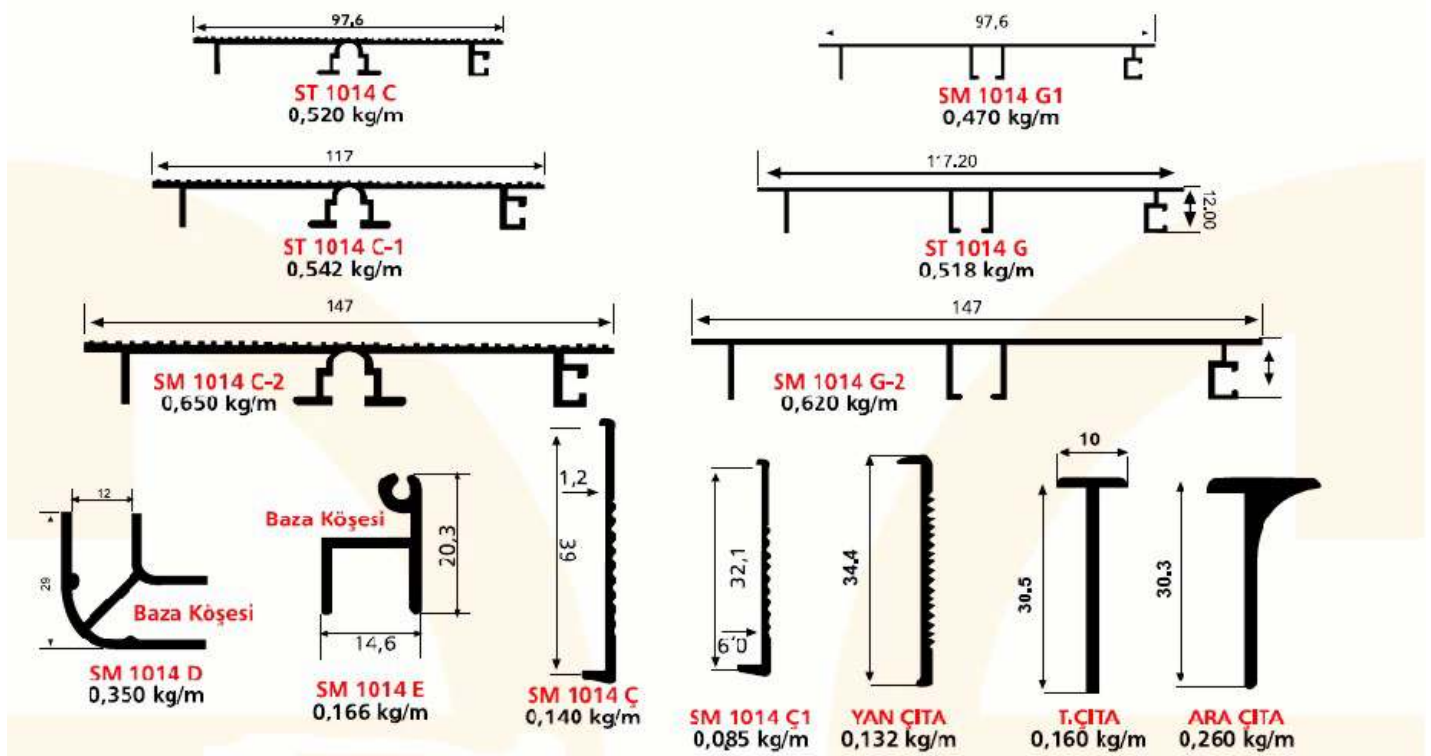

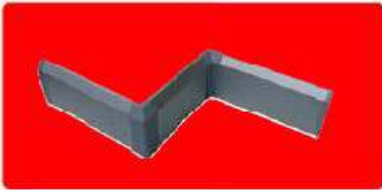
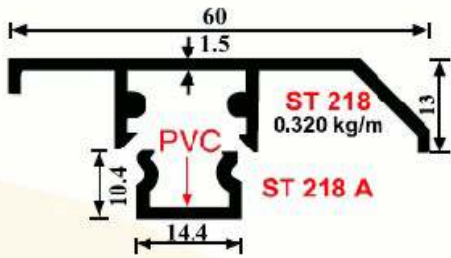

218



219 S

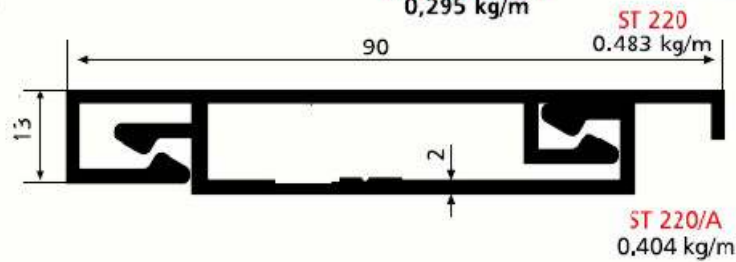
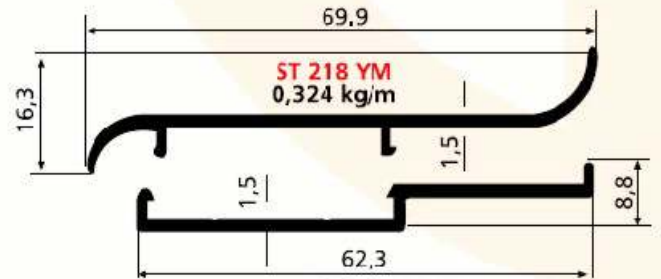
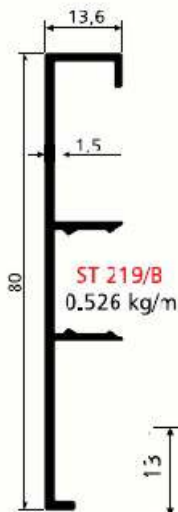
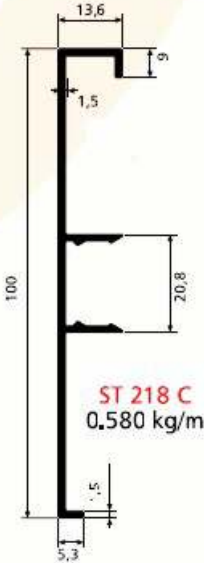
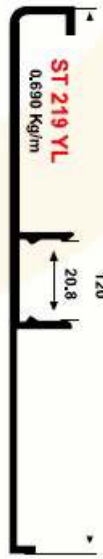
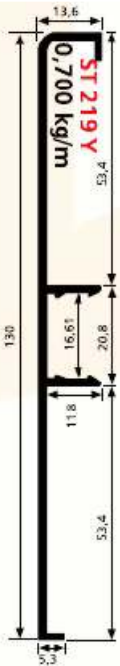
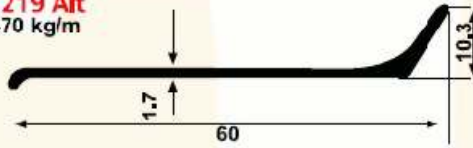
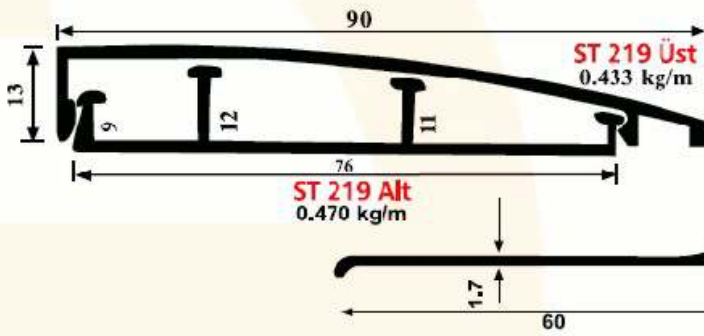
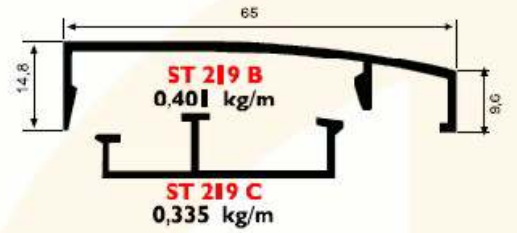
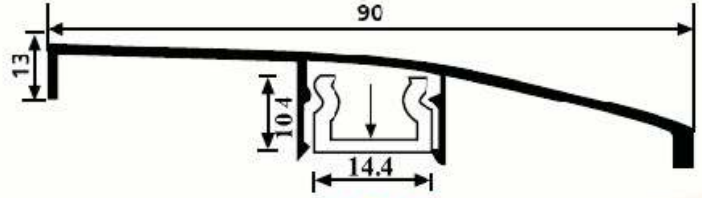

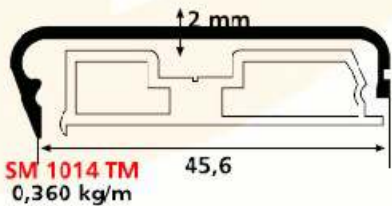
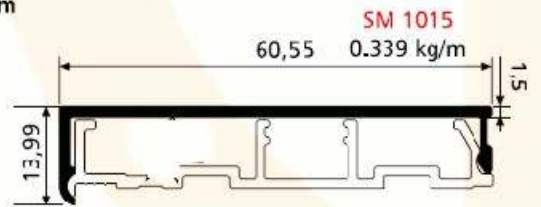
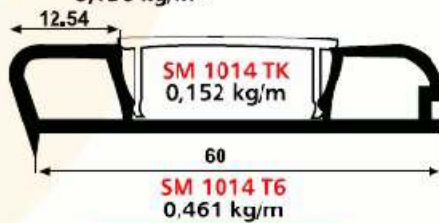
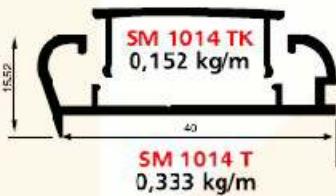
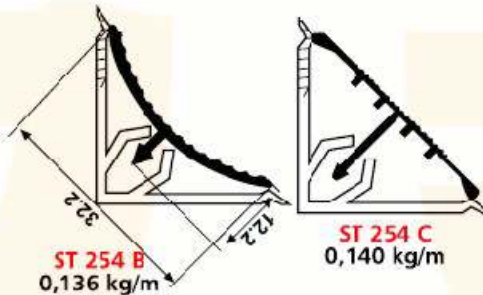
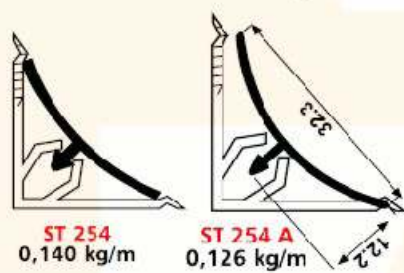
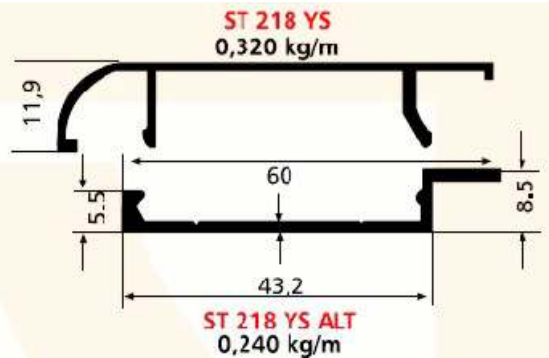
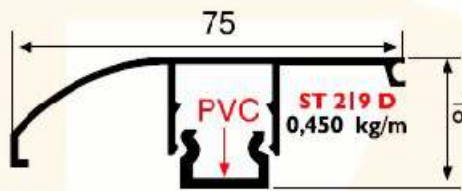

SM 1014 T - 1014 T6

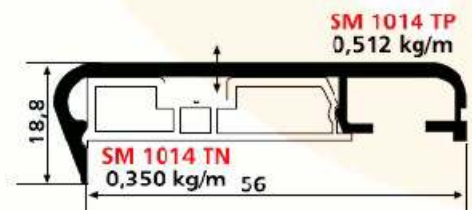

PROFILE AMENAJARI INTERIOARE

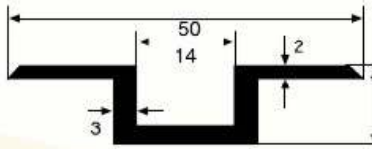

SM 1017
0,470 kg/m

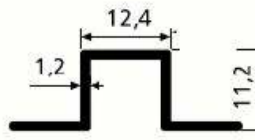

SM 1017 A
0,180 kg/m

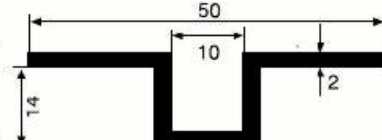

SM 1018
0,440 kg/m

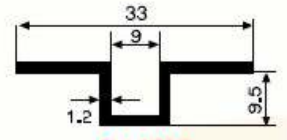

SM 1019
0,200 kg/m

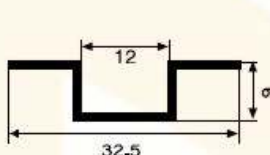

SM 1020
0,135 kg/m

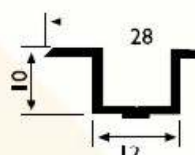

SM 1020 A
0,145 kg/m

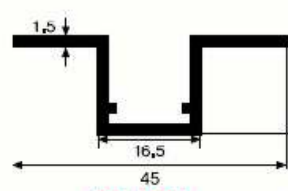

SM 1021
0,315 kg/m

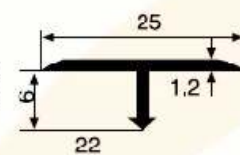

SM 1022
0,100 kg/m

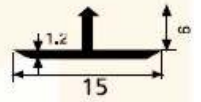

SM 1022 C
0,068 kg/m

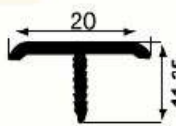

SM 1022 D
0,122 kg/m

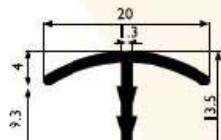

SM 1023 A
0,125 kg/m

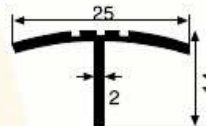

SM 1023
0,097 kg/m

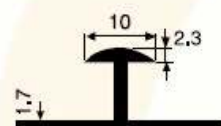

SM 1024
0,220 kg/m

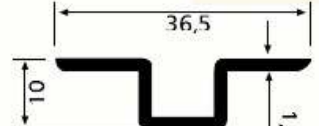

SM 1020 V
0,285 kg/m

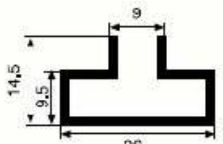

SM 1037
0,220 kg/m

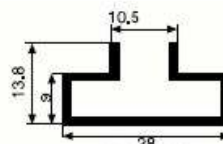

SM 1038
0,220 kg/m

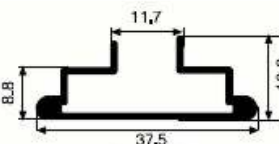

SM 1039
0,235 kg/m

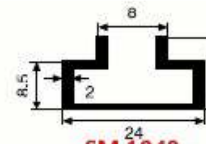

SM 1040
0,210 kg/m

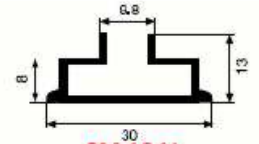

SM 1041
0,185 kg/m

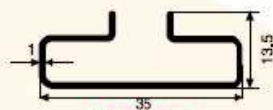

SM 1042
0,210 kg/m

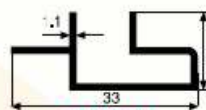

SM 1043
0,195 kg/m

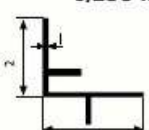

SM 1038 A
0,150 kg/m

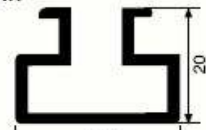

SM 1044
0,360 kg/m

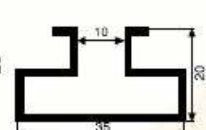

SM 1045
0,433 kg/m

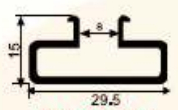

SM 1045 A
0,312 kg/m

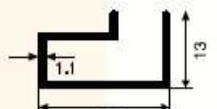

SM 1046
0,185 kg/m

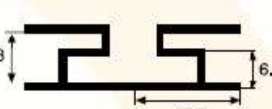

SM 1047
0,356 kg/m

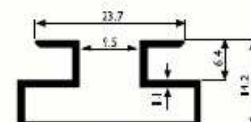

SM 1044 A
0,275 kg/m

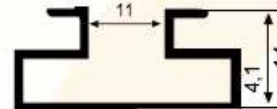

SM 1044 B
0,195 kg/m

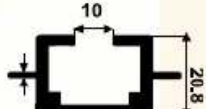

SM 1047 A
0,727 kg/m

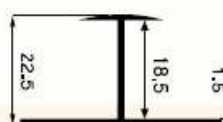

SM 1025 A
0,285 kg/m

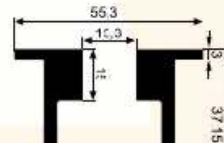

SM 1038 B
1,607 kg/m

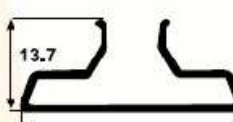

SM 1045 B
0,224 kg/m



SM 1038 B1
0,350 kg/m
SM 1038 B
0,413 kg/m

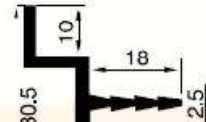

SM 1038 SA
0,485 kg/m

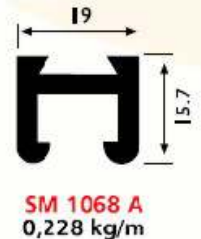
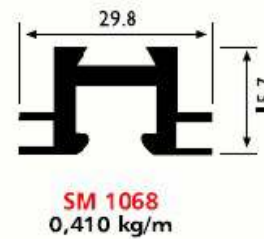
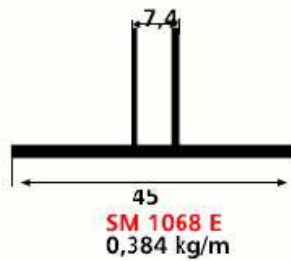
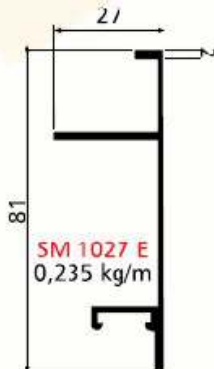
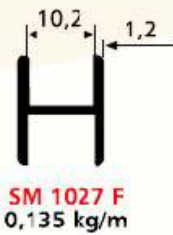
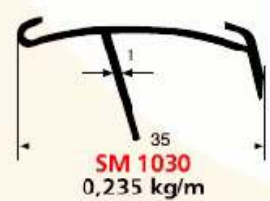
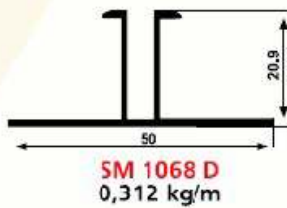
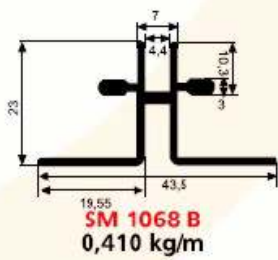
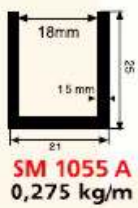
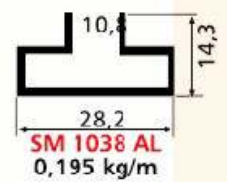
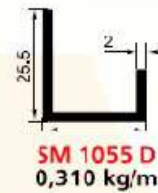
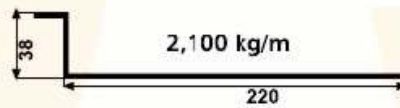
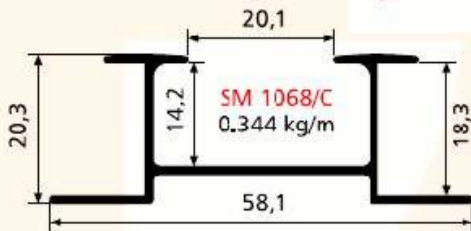
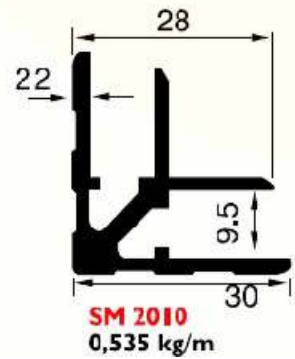
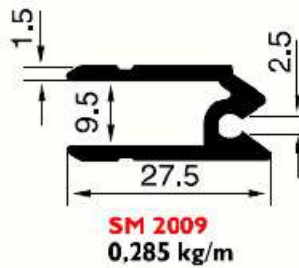
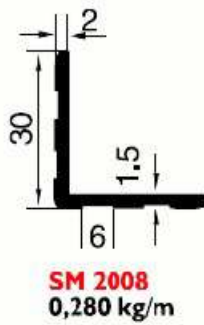
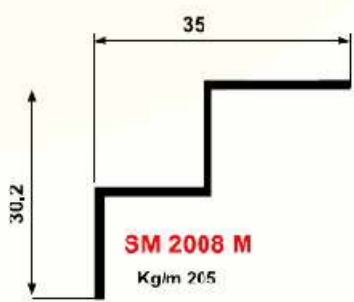

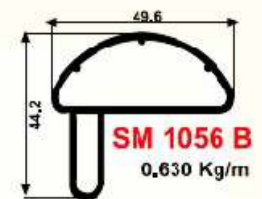
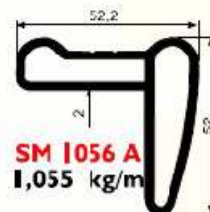
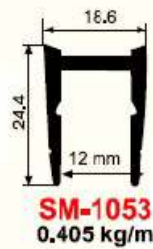
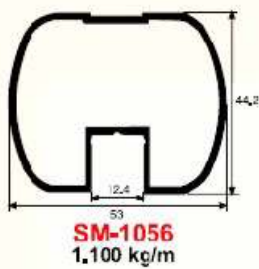
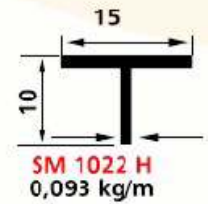
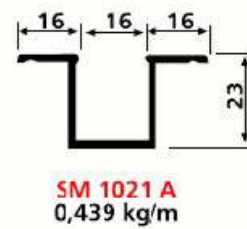
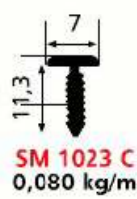
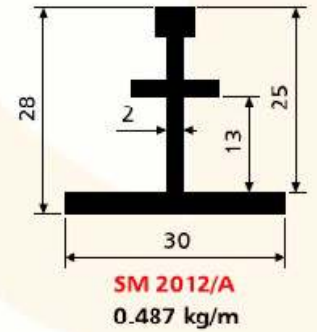
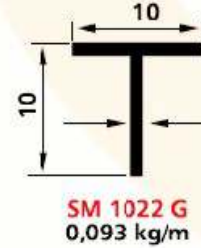
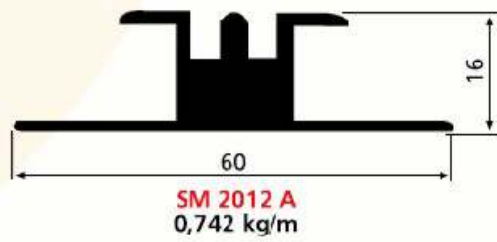
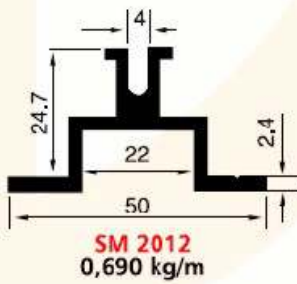
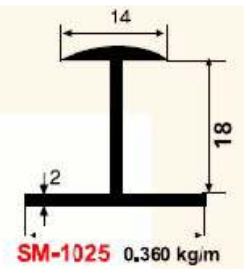
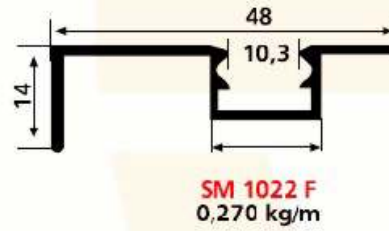
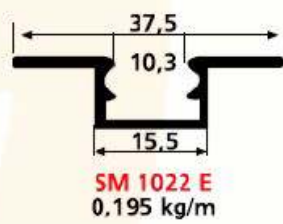
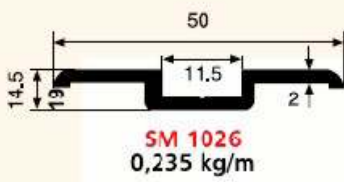
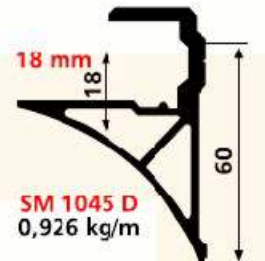
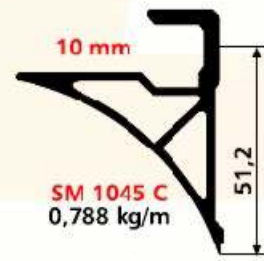
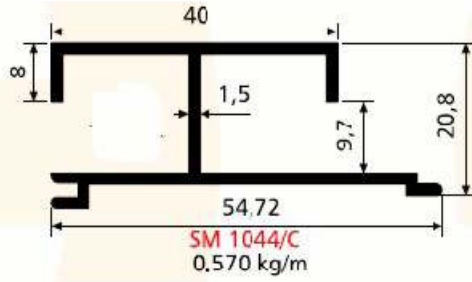
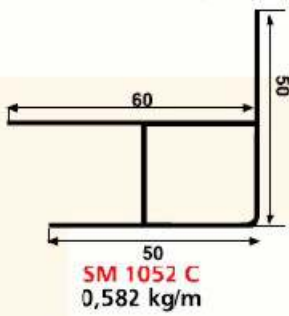

PROFILE pentru STANDURI si AMENAJARI MAGAZINE



Stor U Profili



Stor Kulp Profili



Stor Profili

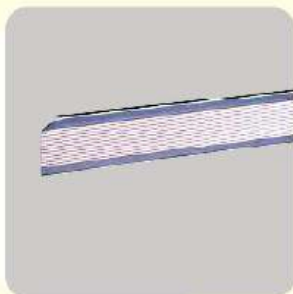

3 Luk



T 3 Luk



3 Luk



1

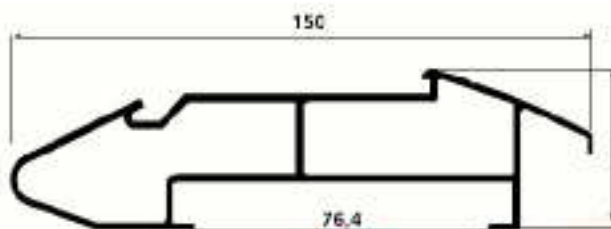
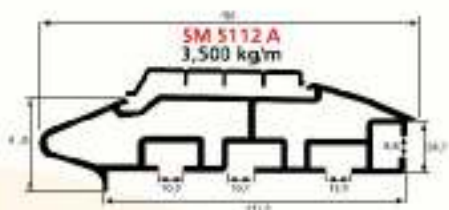

SM 5112 B
1,810 kg/m

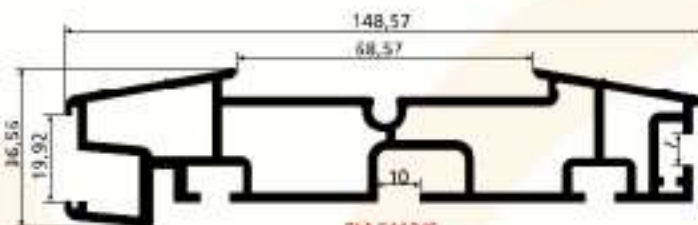

SM 5112/C
2,965 kg/m



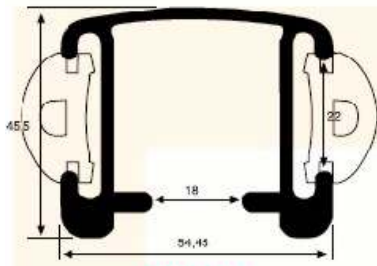

SM 7029
1,615 kg/m

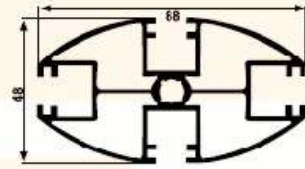

FS 4029
2,048 kg/m

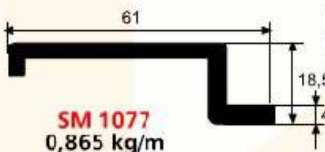

SM 1077
0,865 kg/m

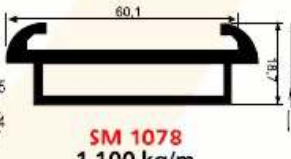

SM 1078
1,100 kg/m



SM 1079
1,100 kg/m

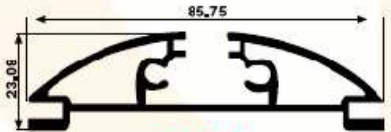

FS 4030
1,044 kg/m

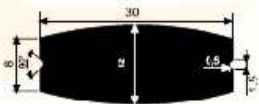

SB 5036
0,865 kg/m

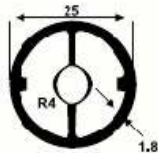

SM 1063 B
0,520 kg/m

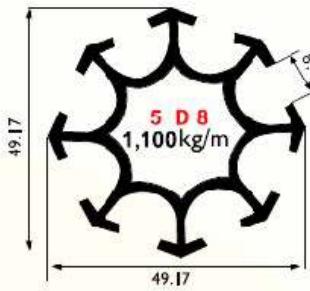
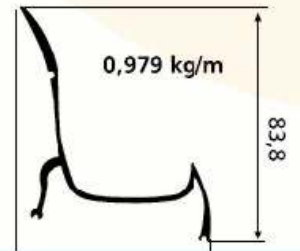

5 D 8
1,100 kg/m

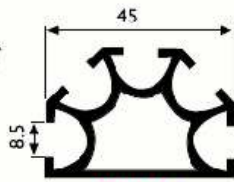

21 D 5
0,900 kg/m

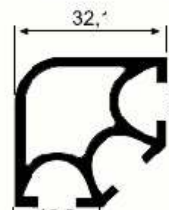

23 D 3
0,670 kg/m

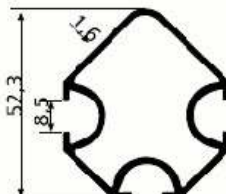

D4
0,895 kg/m

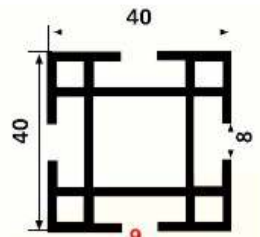

1,3 mm 0,950 kg/m
2 mm 1,350 kg/m

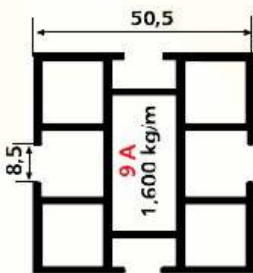

9 A
1,600 kg/m

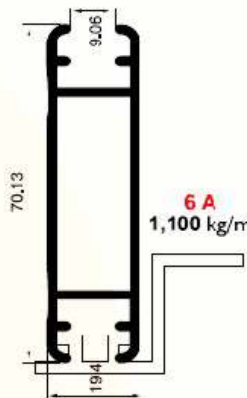

6 A
1,100 kg/m

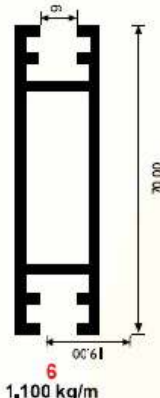

6
1,100 kg/m

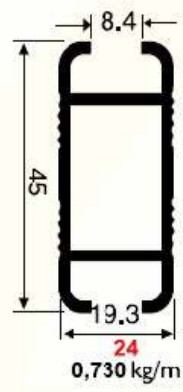

24
0,730 kg/m

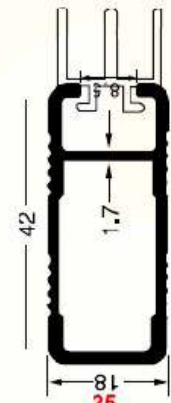

25
0,612 kg/m

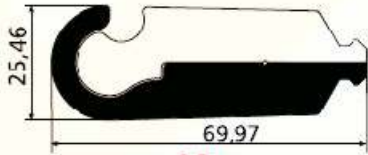
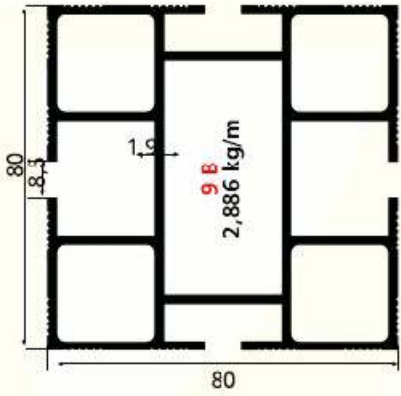

9/B
1,993 kg/m

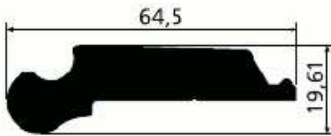

26/B

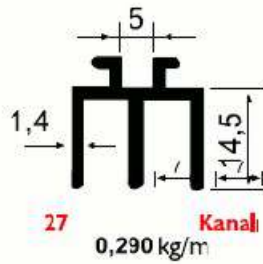
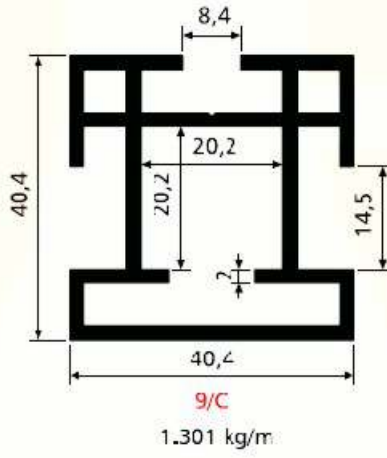

27 Kanal
0,290 kg/m

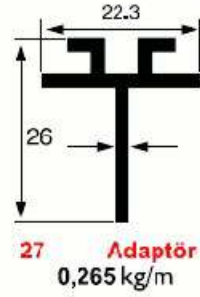
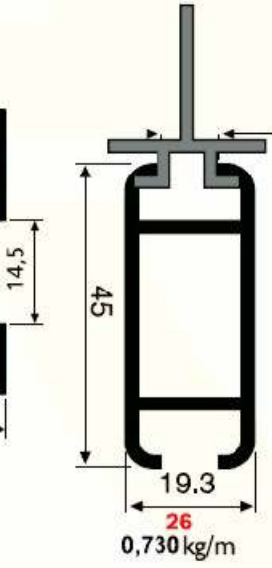

27 Adaptör 1
0,265 kg/m

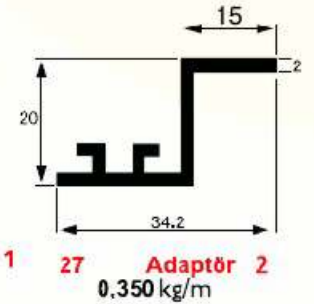

27 Adaptör 2
0,350 kg/m

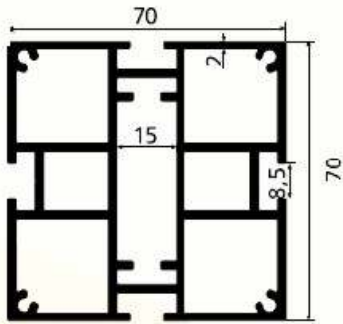
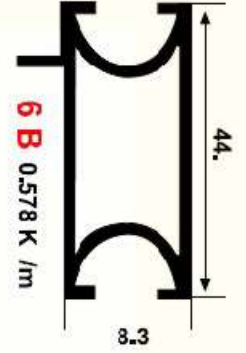

9/D
3,025 kg/m

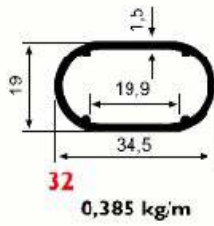

32
0,385 kg/m

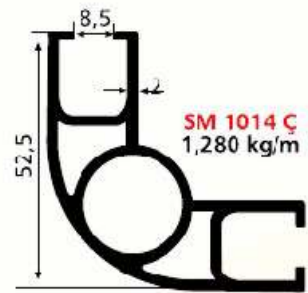

SM 1014 Ç
1,280 kg/m

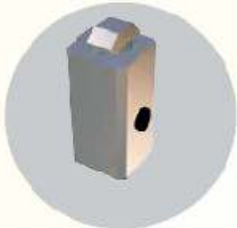

40x40 Sigma



7'



5'

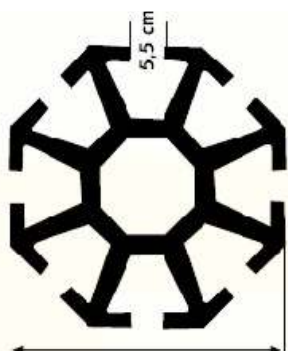

FS 4022
Kg/m 1.366

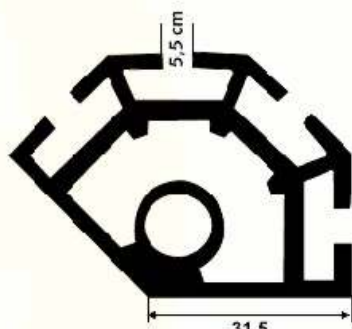

FS 4023
Kg/m 1.504

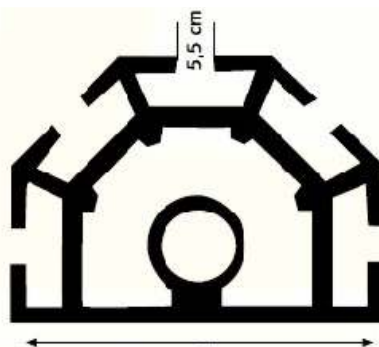

FS 4024
Kg/m 1.66

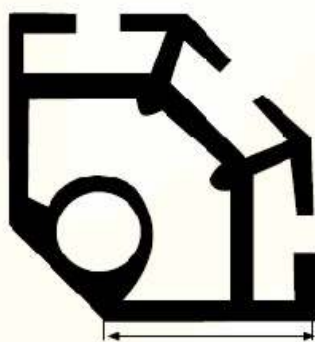

FS 4025 1,210 Kg/m



FS 4026
0.837 Kg/m



FS 4027
1,051 Kg/m



FS 4028
1.896 Kg/m

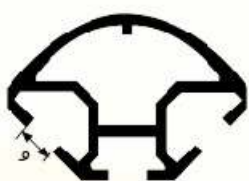

1
0.395 kg/m



3
0.390 kg/m

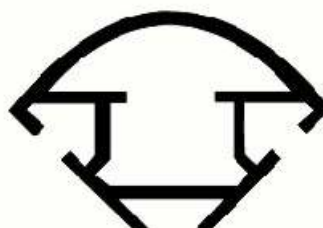

4
0.420 kg/m

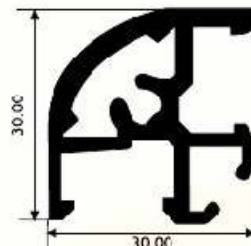

8
0.625 kg/m



2
0.435 kg/m

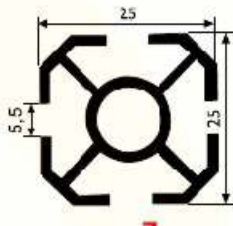

7
0.415 kg/m

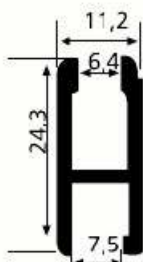

15
0,270 kg/m

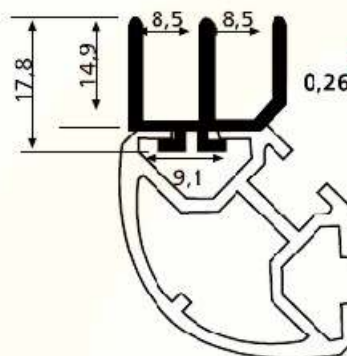

16
0,265 kg/m

28

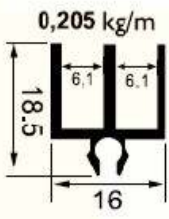

29

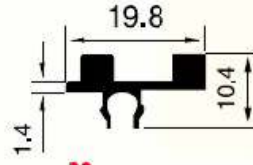
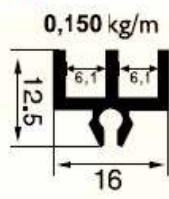

30

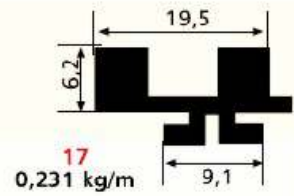

17

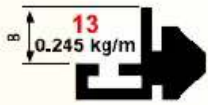

13

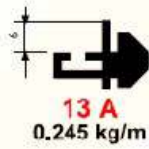

13 A



12

12 A
0,600 kg/m

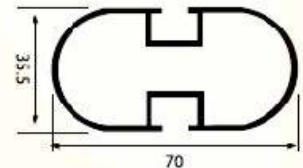

10
0,870 kg/m



Siğma L



FS 4006 A



45x45 Siğma

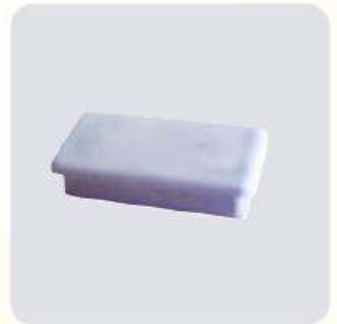

1059

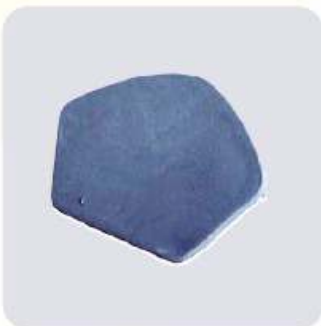

1052



1038 FI



80x80 Siğma



60x60



50x50



40x40



40x40 Sigma



40x40 Sigma



40x40 Sigma



40x40 Sigma

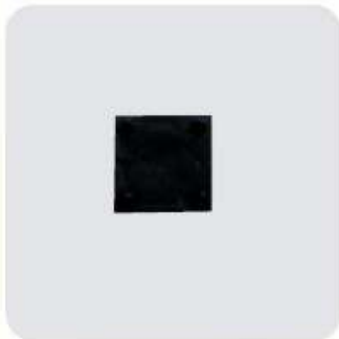

30x30 Sigma



40x40 Sigma



45x45 Sigma



10-12-15 cm



PROFILE si ACCESORII PUBLICITATE

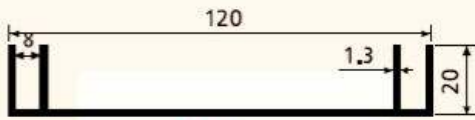

R 108
0,725 kg/m

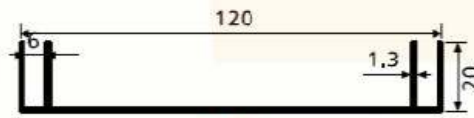

R 109
0,725kg/m

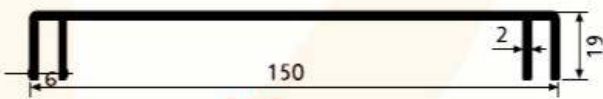

R 110
1,239kg/m

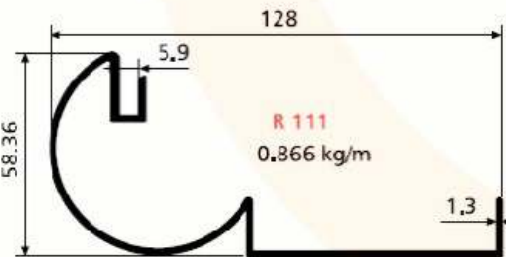

R 111
0,866 kg/m

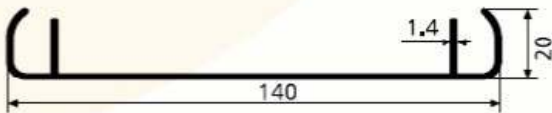

R 112
0,825 kg/m

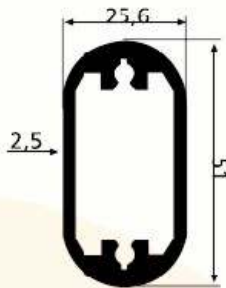

SM 1059
1,130 kg/m

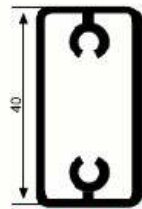

SM 1059 A
0,645 kg/m

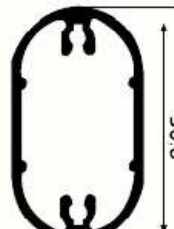

SM 1059 B
0,859 kg/m

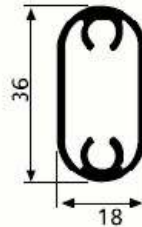

SM 1059 C
0,510 kg/m

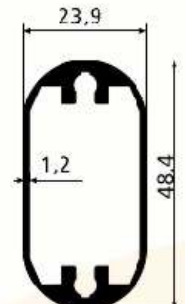

SM 1059 D
0,695 kg/m

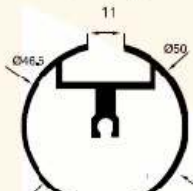

SM 5014
1,103 kg/m

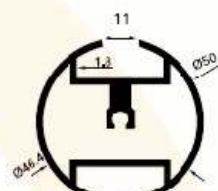

SM 5015
1,230 kg/m



SM-1060 A
0,050 kg/m

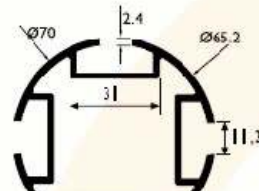

SB 5016
2,237 kg/m



SB 5017
1,527 kg/m

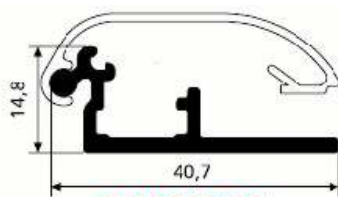

SM 1067/RM
0,363 kg/m

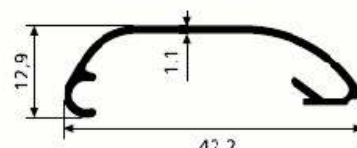

SM 1067/R
0,218 kg/m

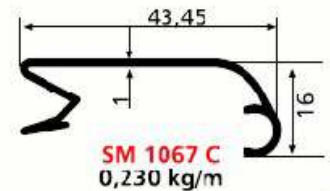
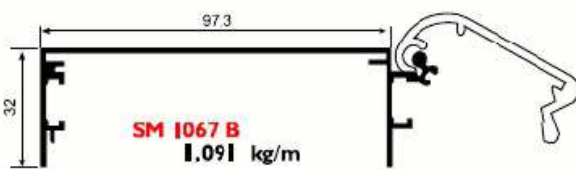
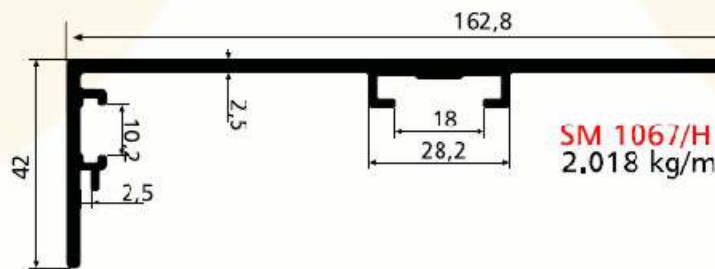
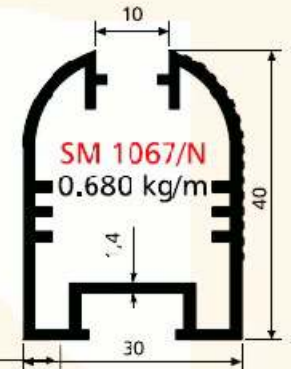
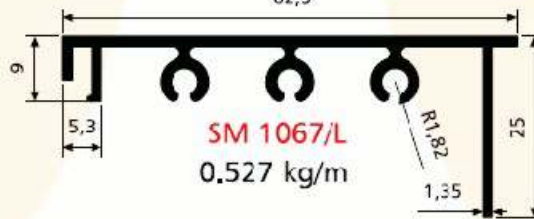
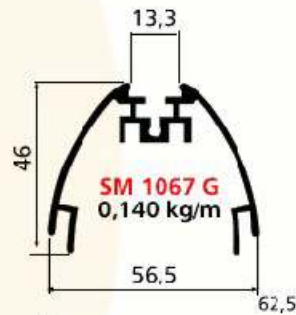
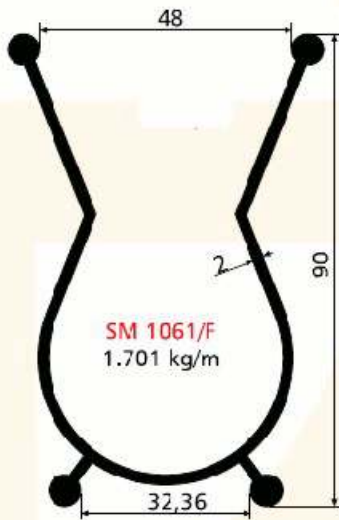

SM 1067 FL
0,160 kg/m

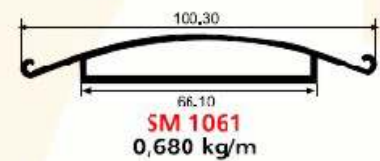
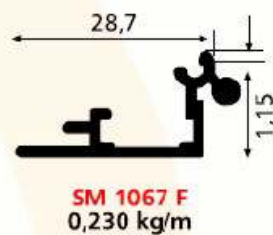
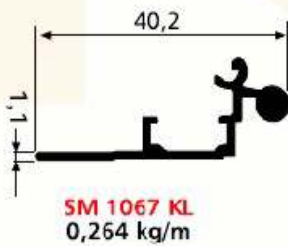
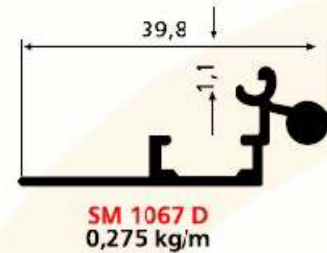

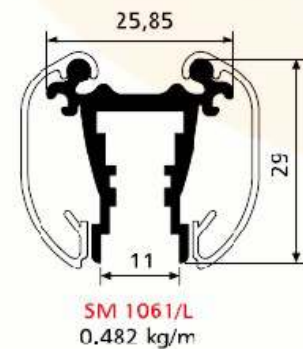
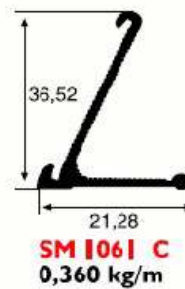
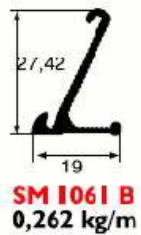
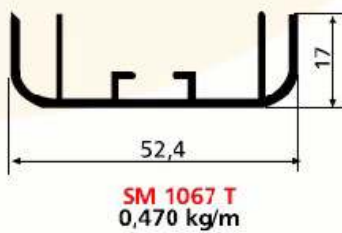
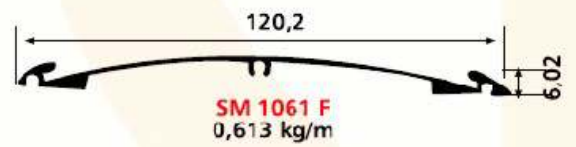
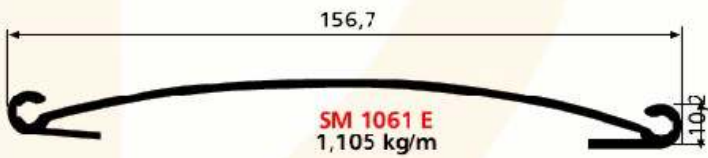
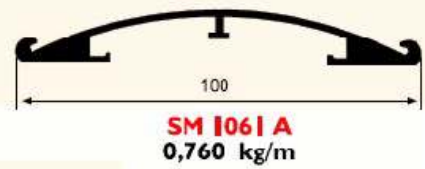
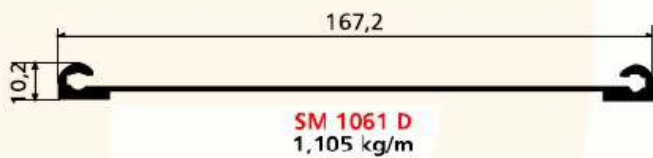
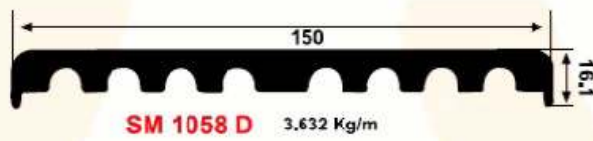
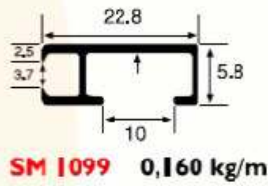
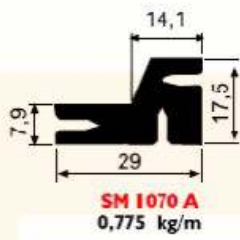

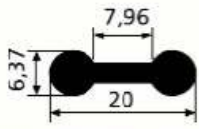

SM 1061/G
0.244 kg/m

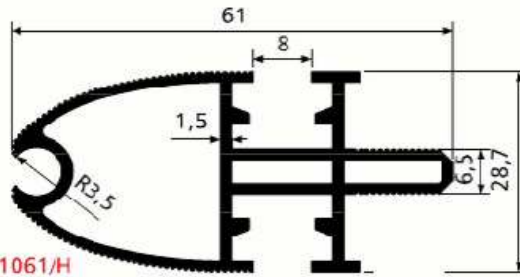

SM 1061/H
1.004 kg/m

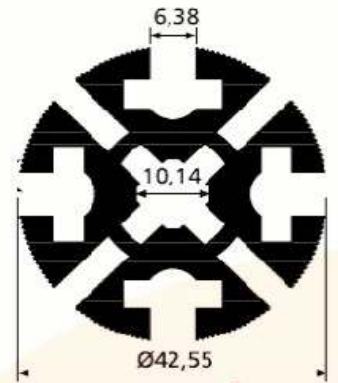

SM 1061 i
1.754 kg/m

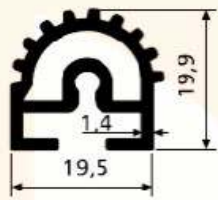

SM 1061/J
0.404 kg/m

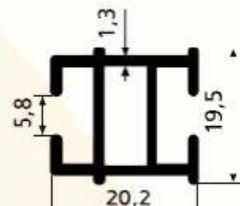

SM 1061/K
0.333 kg/m

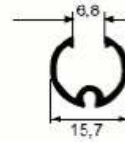

SB 5035
0.130 kg/m

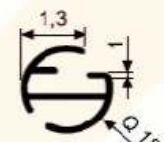

SB 5028
0.185 kg/m

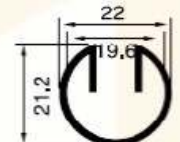

SB 5033
0.240 kg/m

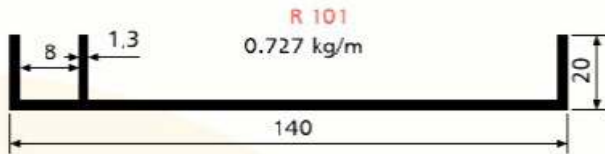

R 101
0.727 kg/m

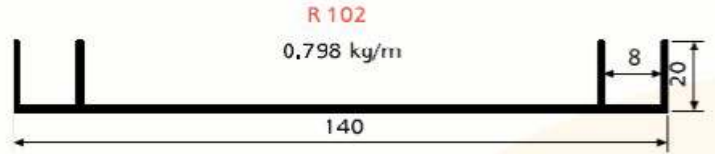

R 102
0.798 kg/m



R 104
1.523 kg/m



R 103
1.129 kg/m

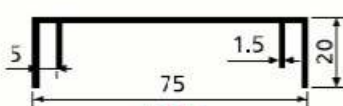

R 105
0.435 kg/m

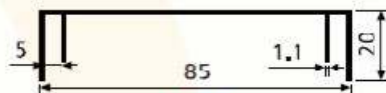

R 106
0.467 kg/m

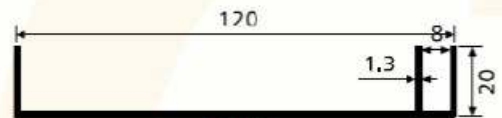

R 107
0.672 kg/m

CUTII SPECIALE si PROFILE TUBULARE

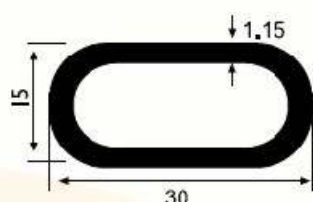

SM 1063
0,235 kg/m

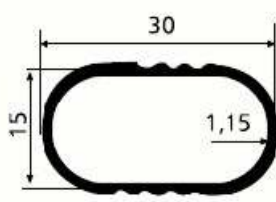

SM 1063 A
0,235 kg/m

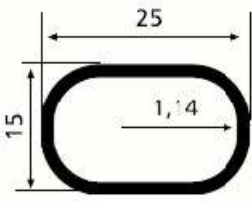

SM 1063 D
0,200 kg/m

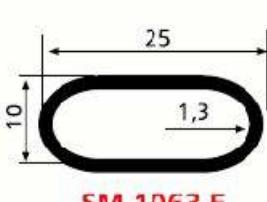

SM 1063 E
0,230 kg/m

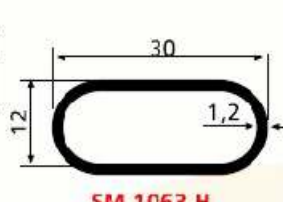

SM 1063 H
0,230 kg/m

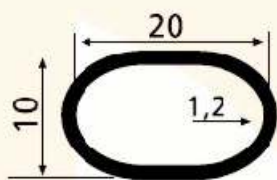

SM 1063 F
0,160 kg/m

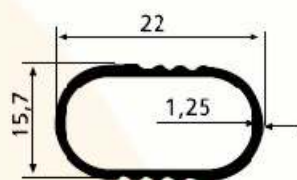

SM 1063 G
0,210 kg/m

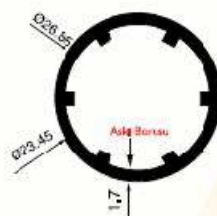

SM 5023
0,413 kg/m

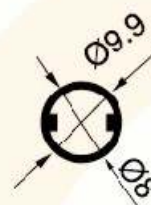

SB 5029
0,183 kg/m

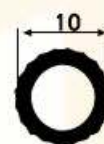

SM 1063 i
0,082 kg/m



SM 1063 J
0,082 kg/m

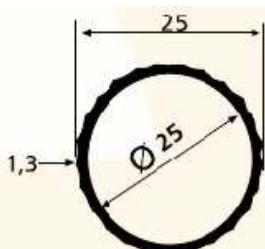

SM 1063 K
0,223 kg/m

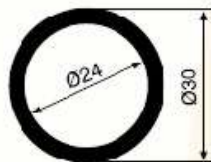

SM 5025
0,687 kg/m

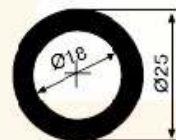

SM 5026
0,638 kg/m



SM 1063 L
0,224 kg/m

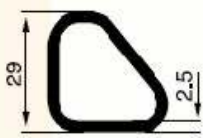

SB 5030
0,590 kg/m

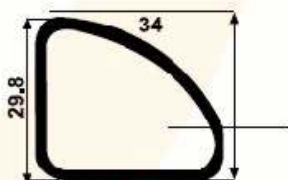

SB 5030 A
0,500 kg/m

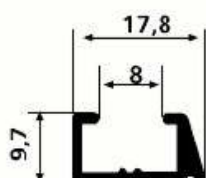

SB 5030 RY
0,150 kg/m

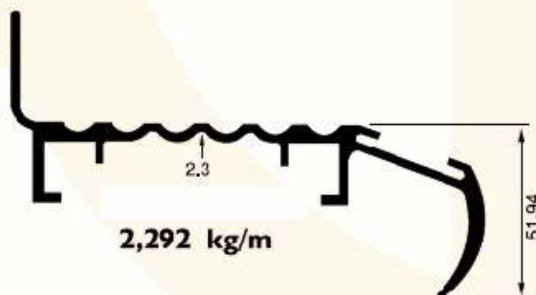

2,292 kg/m

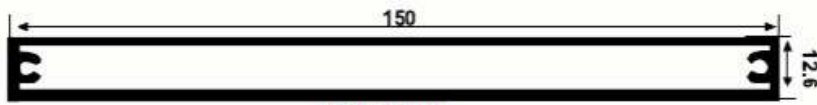

SK 5001 A
1,786 kg/m

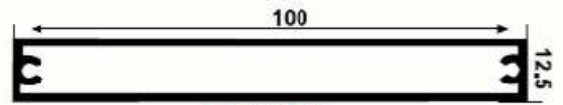

SK 5001 B
0,957 kg/m

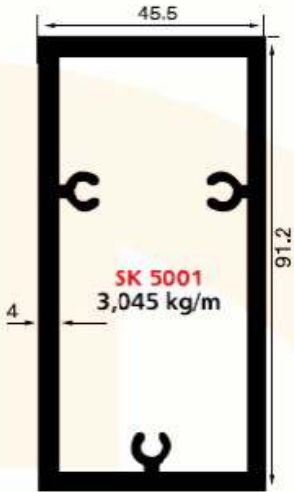

SK 5001
3,045 kg/m

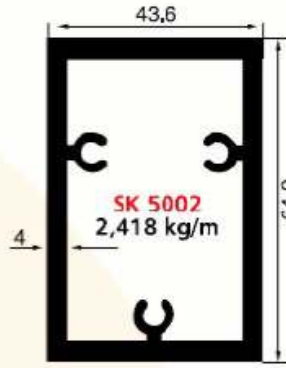

SK 5002
2,418 kg/m

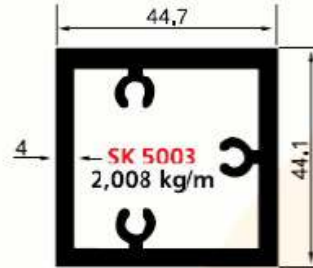

SK 5003
2,008 kg/m



SK 5004
0,500 kg/m

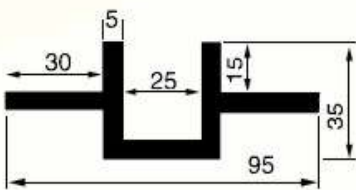

SB 5039
2,100 kg/m

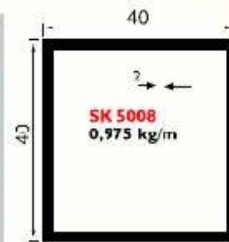
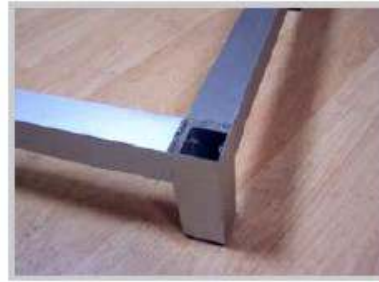

SK 5008
0,975 kg/m

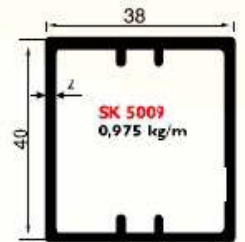

SK 5009
0,975 kg/m

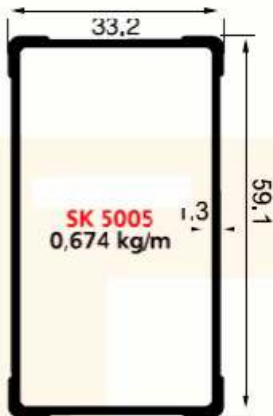

SK 5005
0,674 kg/m

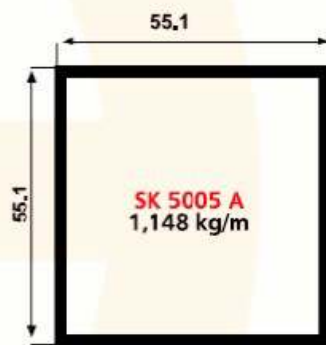

SK 5005 A
1,148 kg/m

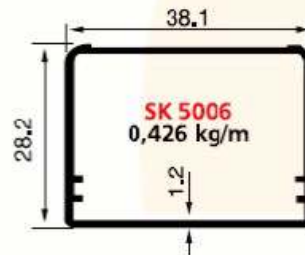

SK 5006
0,426 kg/m

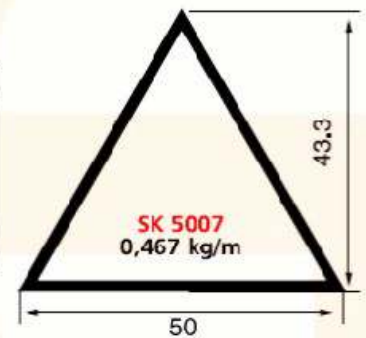

SK 5007
0,467 kg/m

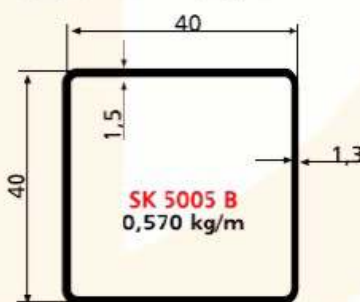

SK 5005 B
0,570 kg/m



SK 5005 C
1,530 kg/m

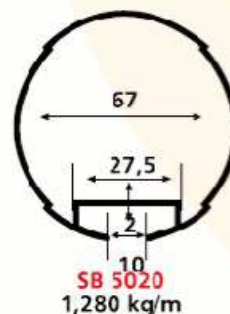

SB 5020
1,280 kg/m

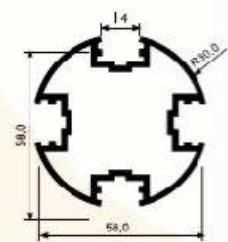

SB 5019
1,504 kg/m

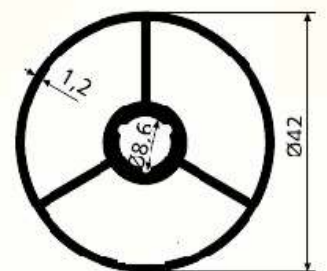
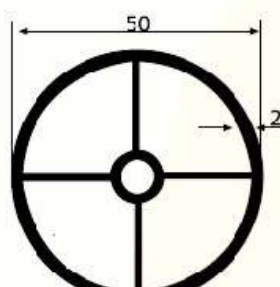
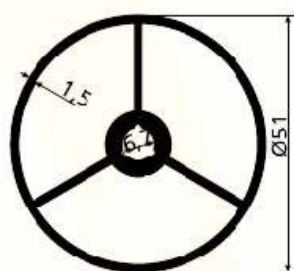
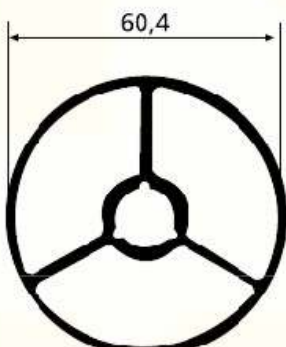
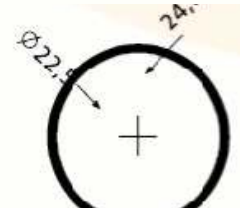
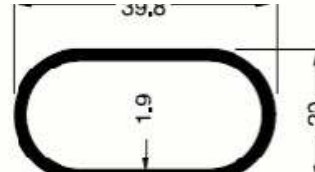
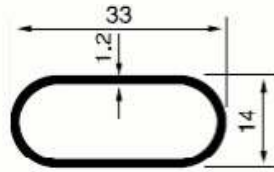
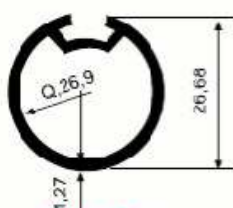
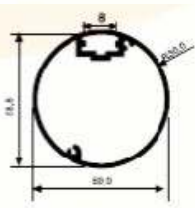
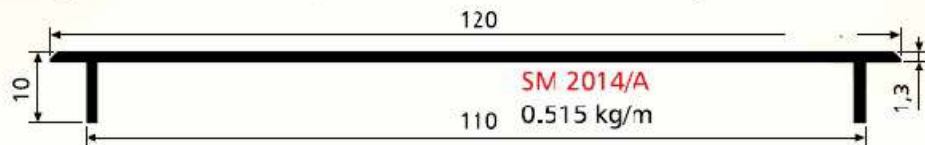
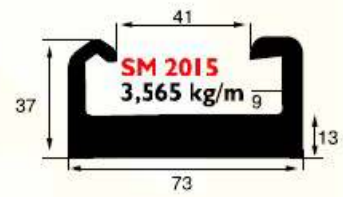
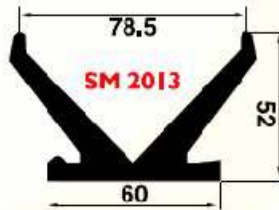
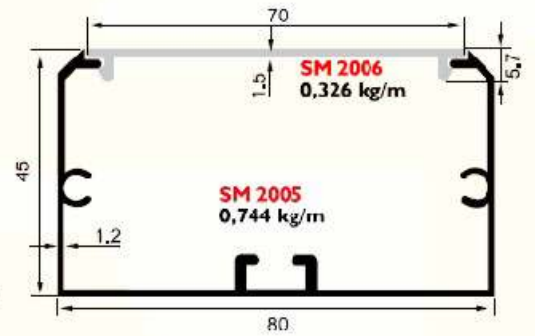
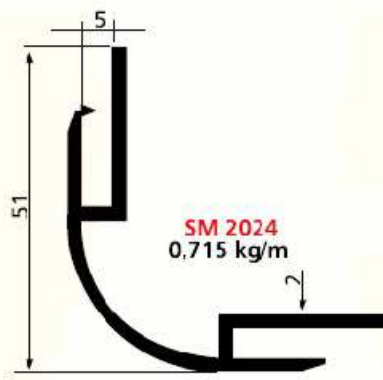
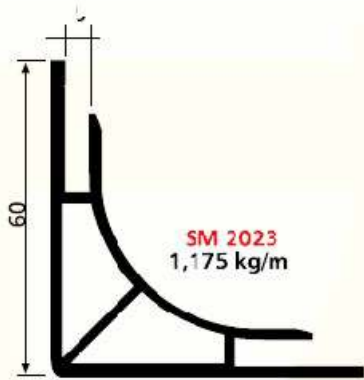

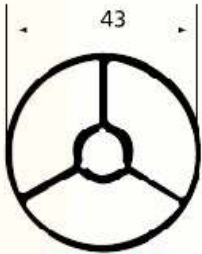

SK 5014 B
0,820 kg/m

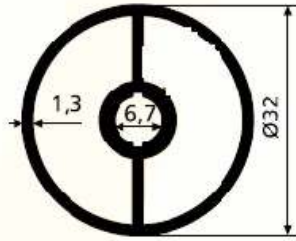

SK 5014/C
0.578 kg/m

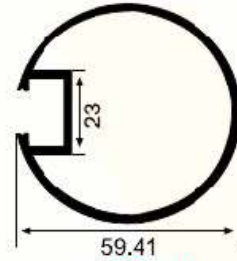

SM 1060
0,155 kg/m

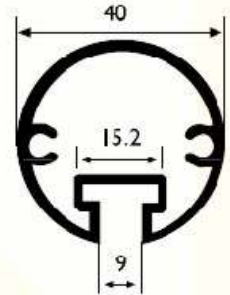

SM 1060 B
0,740 kg/m

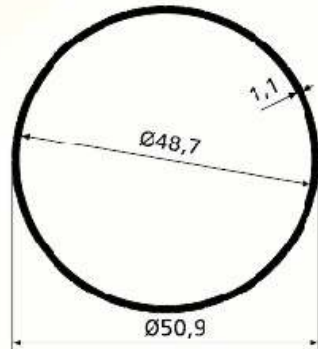

SK 5014 E
0.479 kg/m

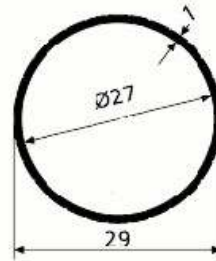

SK 5014 F
0,244 kg/m

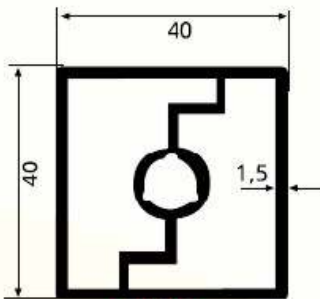

SK 701
0.950 kg/m

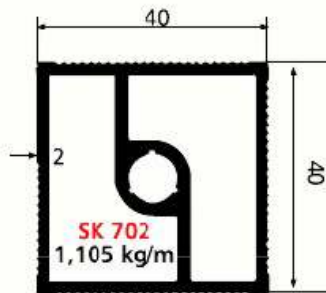

SK 702
1,105 kg/m



SK 703
0.860 kg/m

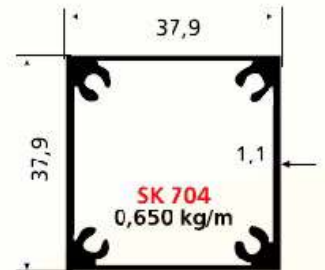

SK 704
0,650 kg/m

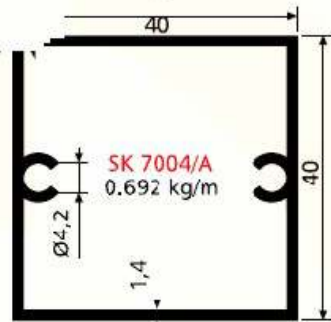

SK 7004/A
0.692 kg/m

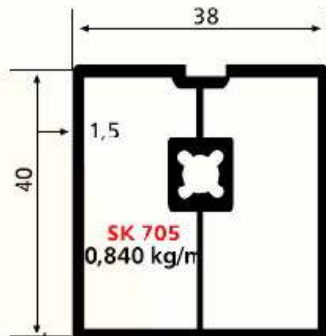

SK 705
0,840 kg/m

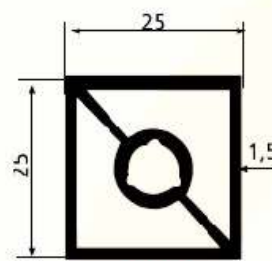

SK 706
0,585 kg/m

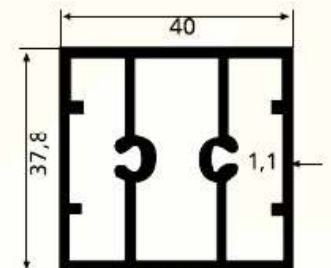

SK 707
0,760 kg/m

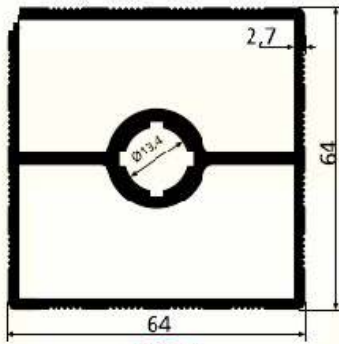

SK 710
0.664 kg/m

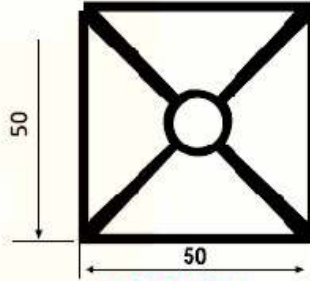

SK 5009 B
1.893 Kg/m

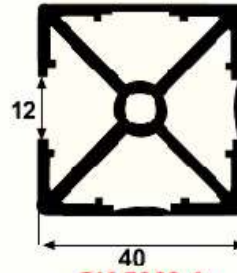

SK 5009 A
1.210 Kg/m

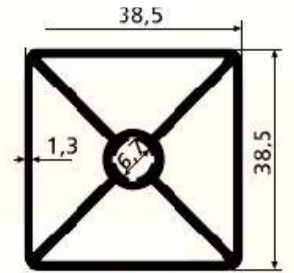

SK 709
1.019 kg/m



SB 5037
1.830 kg/m

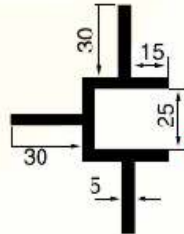

SB 5038
2,510 kg/m

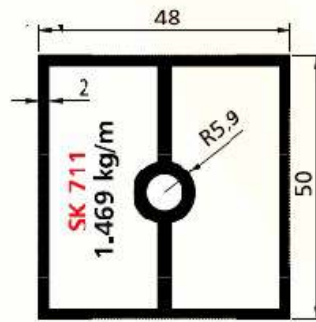

SK 711
1.469 kg/m

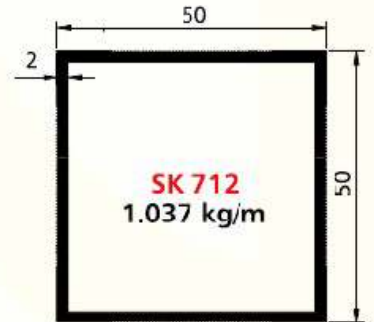

SK 712
1.037 kg/m

CORNIERE si TEVI RECTANGULARE

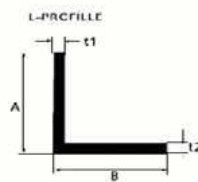

A	B	t1	t2	kg/m	Profil No
15	10	1,5	1,5	0,095	101
15	15	1,5	1,5	0,115	102
15	15	2	2	0,151	119
20	15	1,5	1,5	0,136	103
20	20	1,2	1,2	0,126	104
20	20	1,8	1,8	0,186	125
22	22	3	3	0,332	3622
25	10	2	2	0,178	5791
25	15	3	3	0,473	6861
25	16	3	3	0,308	116
25	25	1,2	1,2	0,158	105
25	25	3	3	0,381	113
25	25	4	4	0,497	6871
30	15	1,4	1,4	0,165	106
30	15	2	2	0,232	6852
30	20	1,25	1,25	0,166	126
30	20	2	2	0,259	3306
30	30	1,2	1,2	0,191	107
30	30	3	3	0,462	108
32	20	2	2	0,270	3834
33	15	3	3	0,365	4301
35	25	2,5	2,5	0,388	4302
39,5	13	3	3	0,402	3694
40	15	1,8	1,8	0,259	124
40	15	3	3	0,421	114
40	20	1,2	1,2	0,191	109
40	20	2	2	0,313	3310
40	30	3	3	0,543	5595
40	40	2	2	0,421	3311
40	40	4	4	0,821	110
50	20	2	2	0,367	118
50	50	3	3	0,632	3314
50	50	5	5	1,283	111
60	20	1,25	1,25	0,266	143
60	30	3	3	0,707	6417
60	60	4	4	1,258	5602
60	60	6	6	1,847	112
75	20	1,5	1,5	0,379	142

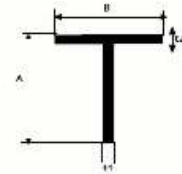

L	t	kg/m	Profil No
10	10	0,270	5279
15	15	0,608	6855
15,2	5	0,205	5603
20	3	0,162	501
20	5	0,270	502
20	6	0,324	5714
21,2	5,2	0,298	524
22	7	0,426	518
23	23	1,428	516
24	6	0,389	565
24	24	1,555	520
25	2	0,135	3300
25	4	0,270	7115
25	5	0,338	504
28	26	1,966	522
30	2	0,162	3301
30	3	0,243	505
30	5	0,405	506
30	7	0,567	500
30	10	0,810	574
30	20	1,620	5713
30	30	2,430	3858
40	1,5	0,162	6803
40	2	0,216	3302
40	3	0,324	507
40	5	0,540	508
40	7	0,756	6867
40	9	0,972	519
40	10	1,080	517
40	12	1,296	3907
40	15	1,620	6819

L	t	kg/m	Profil No
50	3	0,405	557
50	5	0,675	509
50	10	1,350	515
50	12	1,620	3906
53	8	1,145	5600
55	6	0,891	3896
60	1,7	0,275	1935
60	5	0,810	510
60	10	1,620	561
60	20	3,240	559
60	40	6,480	521
70	5	0,945	511
70	15	2,835	6204
75	1,8	0,365	525
80	5	0,108	512
80	8	3,303	3303
80	10	2,160	526
90	5	1,215	6833
100	5	1,350	514
100	10	2,700	513
100	20	5,400	555
120	10	3,240	4600
127	3	1,029	523
130	10	3,510	556
140	3,5	1,323	2120
150	5	2,025	558
160	20	8,640	3872
160	25	10,800	3897
200	10	5,400	3304

A	B	t1	t2	kg/m	Profil No
15	15	1,2	1,2	0,093	215
15	30	1,5	1,5	0,176	6832
20	20	1,2	1,2	0,126	202
25	25	1,2	1,2	0,158	203
25	25	1,5	1,5	0,237	209
25	25	2	2	0,259	211
25	25	2,8	2,8	0,357	230
30	20	1,5	1,5	0,196	208
30	30	1,2	1,2	0,191	204
30	30	3	3	0,462	205
30	30	4	4	0,605	217
32,4	19,8	2,6	2,6	0,340	4561
35	30	1,8	1,8	0,307	206
35	35	1,2	1,2	0,223	225
40	30	3	3	0,543	210
40	40	4	4	0,820	225
50	50	5	5	1,283	3865
60	60	1,5	1,5	0,480	6914
60	60	5	5	1,553	3306

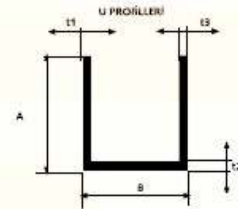

D	kg/m	Profil No
5	0,053	352
10	0,212	305
12	0,305	302
13	0,358	313
14	0,415	304
16	0,543	306
18	0,687	308
19	0,765	309
19,8	0,831	442
20	0,848	311
24,5	1,272	441
25	1,325	316
27	1,545	6860
30	1,908	314
35	2,596	328
40,4	3,459	317
42	3,739	3905
45	4,292	337
50	5,299	318
51,5	5,621	307
55	6,411	3875
50	7,630	319
52	8,147	3973
75	11,922	6545

A	B	t1	t2	kg/m	Profil No
10	20	2	2	0,194	606
10	23	1,5	1,5	0,165	6038
15	15	1,9	1,9	0,211	5798
15	30	1,4	1,4	0,216	3879
17	17	1,2	1,2	0,157	607
20	17	1,3	1,3	0,192	2932
22	150	2	2	1,031	5282
25	21	1,2	1,2	0,222	601
25	36,5	2	2	0,621	1067
30	20	1,6	1,6	0,332	3321
40	50	4	4	1,320	3325

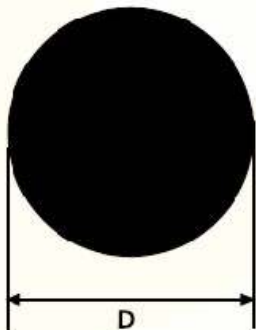

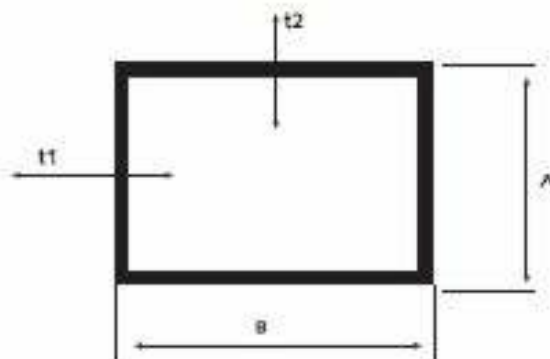

Profile rectangulare

A	B	t1	t2	kg/m	Profil No
10	20	1,5	1,5	0,219	1800
14	14	1	1	0,155	63
15	15	1,5	1,5	0,219	3887
17	25	1,3	1,3	0,277	8
17	27	2	2	0,432	3881
20	40	1,3	1,3	0,403	6
20	40	2	2	0,605	6205
20	45	1,8	1,8	0,597	18
20	50	1,3	1,3	0,473	30
20	50	1,8	1,8	0,645	28
20	60	1,8	1,8	0,743	19
20	80	1,25	1,25	0,658	52
20	100	1,8	1,8	1,005	6942
25	40	1,3	1,3	0,438	3
25	45	1,3	1,3	0,473	33
25	50	1,8	1,8	0,694	27
25	65	1	1	0,440	65
25	75	1,5	1,5	0,786	20
30	30	1,4	1,4	0,432	4
30	30	1,5	1,5	0,462	44
30	80	1,5	1,5	0,867	25
32	75	1,3	1,3	0,733	5
35	55	3	3	1,361	29
40	40	1,2	1,2	0,503	7
40	40	2	2	0,821	32

A	B	t1	t2	kg/m	Profil No
40	50	1,2	1,2	0,563	39
40	50	1,6	1,6	0,750	9
40	40	1	1	0,421	3885
40	40	1,1	1,1	0,462	6851
40	60	1,25	1,25	0,458	46
40	60	3	2	1,231	50
40	80	1,5	1,5	0,948	22
40	80	2	2	1,253	40
40	100	2	2	1,469	23
45	70	2	2	1,119	2112
45	90	2	2	1,415	2113
50	50	1,8	1,8	0,937	16
50	50	3	3	1,523	26
50	95	1,5	1,5	1,150	42
50	95	2	2	1,523	21
50	100	2	2	1,577	6913
50	150	2	2	2,120	66
53	53	3,5	3,5	1,870	7266
59	59	1,8	1,8	1,112	31
60	120	1,8	1,8	1,715	24
70	70	4	4	2,851	34
80	80	2	2	1,685	80
100	100	2,5	2,5	2,633	100

BORU PROFİLLERİ

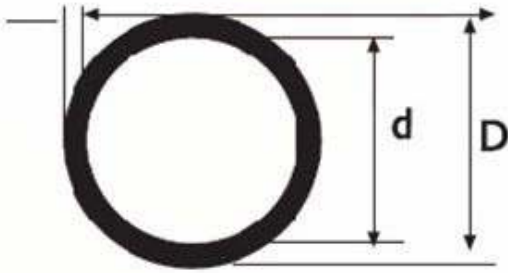

C	d	t	kg/m	Profil No
10	4,2	2,9	0,176	7267
10	6	2	0,138	6052
14	6,5	3,75	0,326	404
14	12	1,2	0,130	6653
16	6	5	0,466	462
16	6,5	4,75	0,453	468
16	7	4,5	0,439	415
16	11	2,5	0,286	431
16	13	1,35	0,167	6651
16	12	2	0,237	433
18	10	3,85	0,465	2468
19.1	16	1,5	0,224	463
20	16	2	0,305	6284
20	8	6	0,712	471
20	10	5	0,636	470
20	14	3	0,432	409
20	17	1,5	0,235	402
22	8	7	0,890	475
22	10	6	0,814	474
22	14	4	0,610	473
22	16	2,88	0,466	6839
22	17	1,5	0,413	472
22	18	2	1,339	401
22.2	20	1,37	0,242	467
23.5	22	1	0,191	6835
25	8	8,5	0,189	481
25	10	1,5	1,113	480
25	14	5,5	0,909	479
25	17	1	0,712	478
25	18	3,5	0,638	477
25	20	2,5	0,477	476
25	21	2	0,390	3318
25	22	1,5	0,299	408
25	23	1,25	0,252	403
25	23	0,85	0,174	6843
26	14	6	1,017	485
26	17	4,5	0,820	484
26	18	4	0,746	483

D	d	t	kg/m	Profil No
30	20	5	1,060	489
30	22	4	0,882	488
30	24	3	0,687	457
30	26	2	0,479	3319
32	26	3	0,738	420
32	22	5	1,145	2465
35	29	3	0,814	438
35	8	14	2,461	426
35	25	5	1,272	424
38	12	13	2,755	405
40	45	18	3,350	440
40	25	7,5	2,067	458
40	34	3	0,941	465
40	35	2,5	0,795	407
40	36	2	0,644	3320
40	37	1,3	0,427	6364
40	10	15	3,213	411
40	30	5	1,479	412
41	38	1,4	0,454	435
42	30	6	1,031	452
45	20	12	3,419	413
45	40	2,4	0,850	428
50	30	10	3,391	6368
50	42	4	1,560	453
50	44	3	1,195	429
50	45	2,5	1,007	460
50	46	2	0,814	427
50	47	1,3	0,537	6365
55	10,5	7,25	2,935	430
55	50	2,5	1,113	461
60	20	20	6,782	496
60	30,5	14,75	5,659	6348
60	54	3	1,450	425
60	55	2,5	1,219	423
65	60	2,5	1,326	3910
65	60,3	2,35	1,248	414
70	40,2	14,9	6,960	6318
70	40,5	14,75	6,909	6349

UTILITARE "SYGMA" si "CONVEYOR"

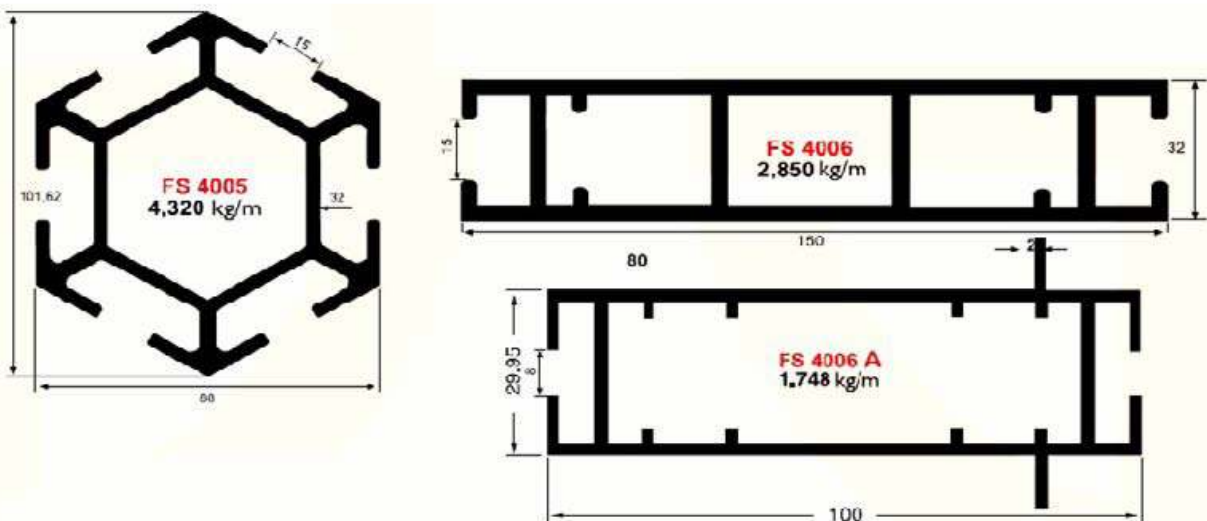
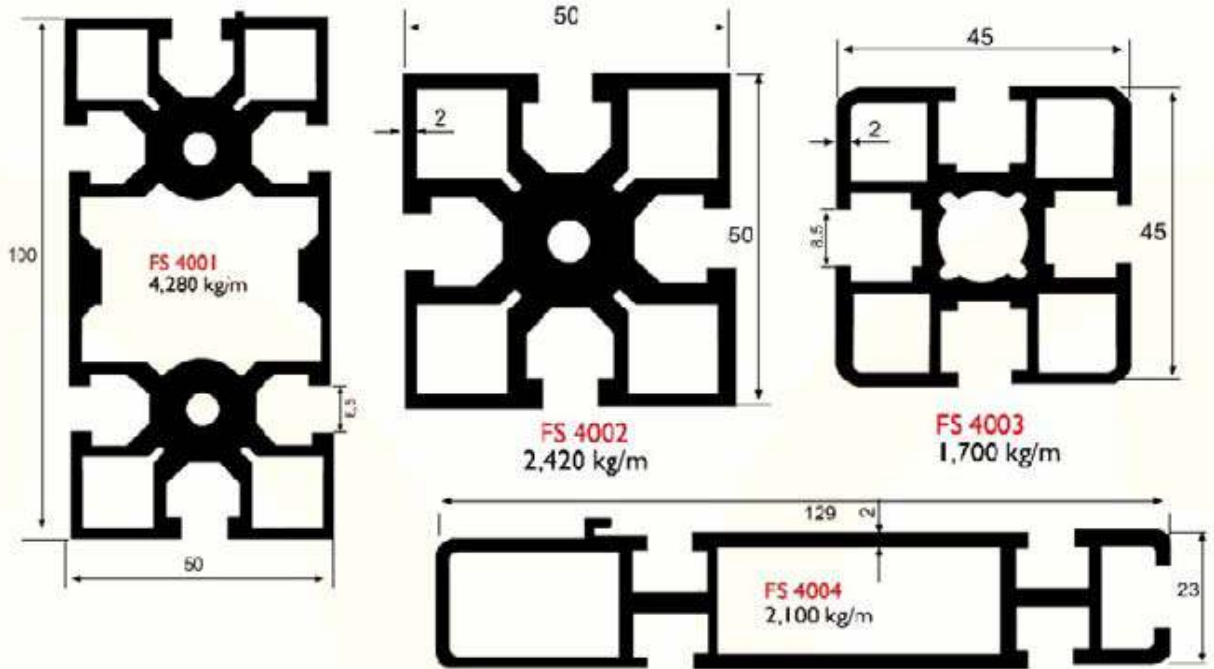
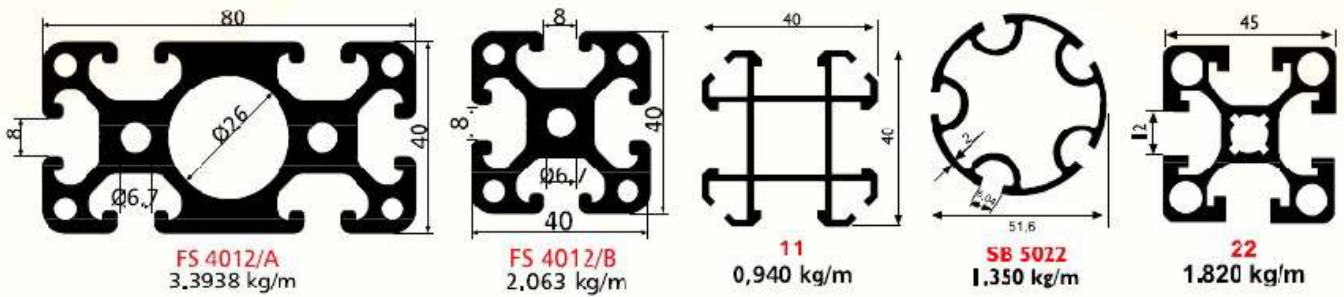

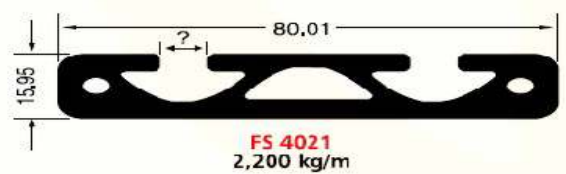
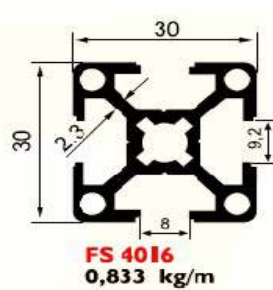
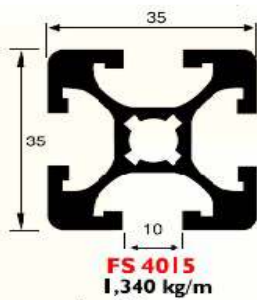
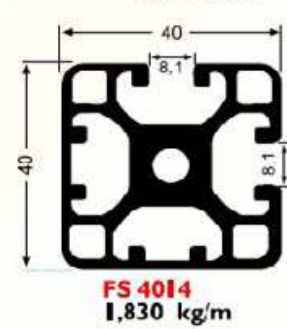
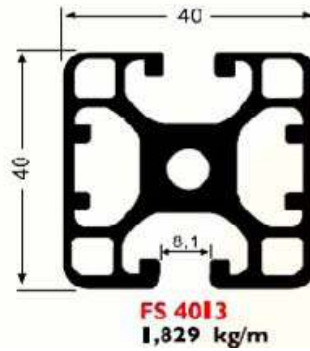
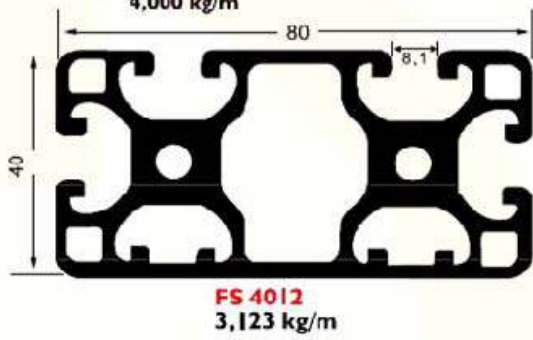
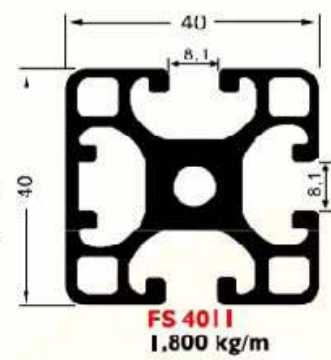
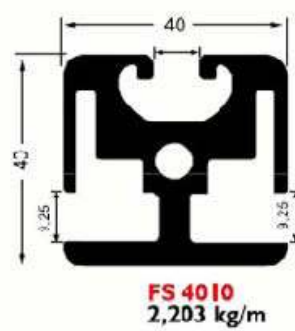
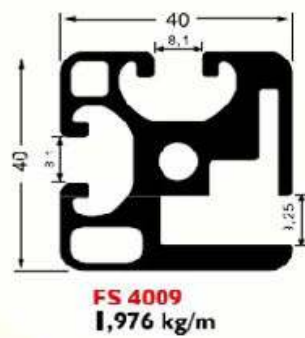
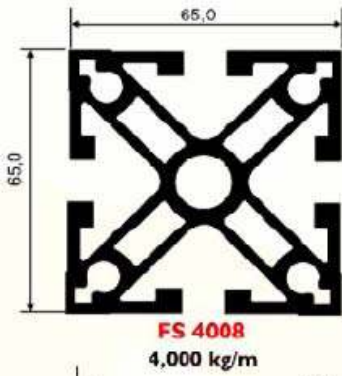
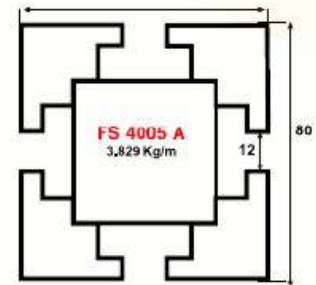
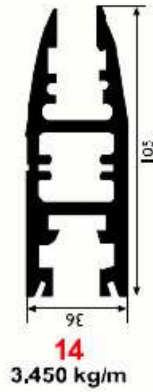
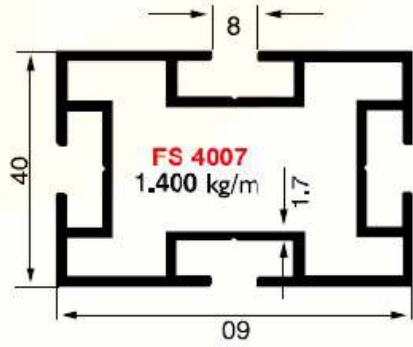

PARASOLARE și ACOPERIRI CERAMICE CLADIRI

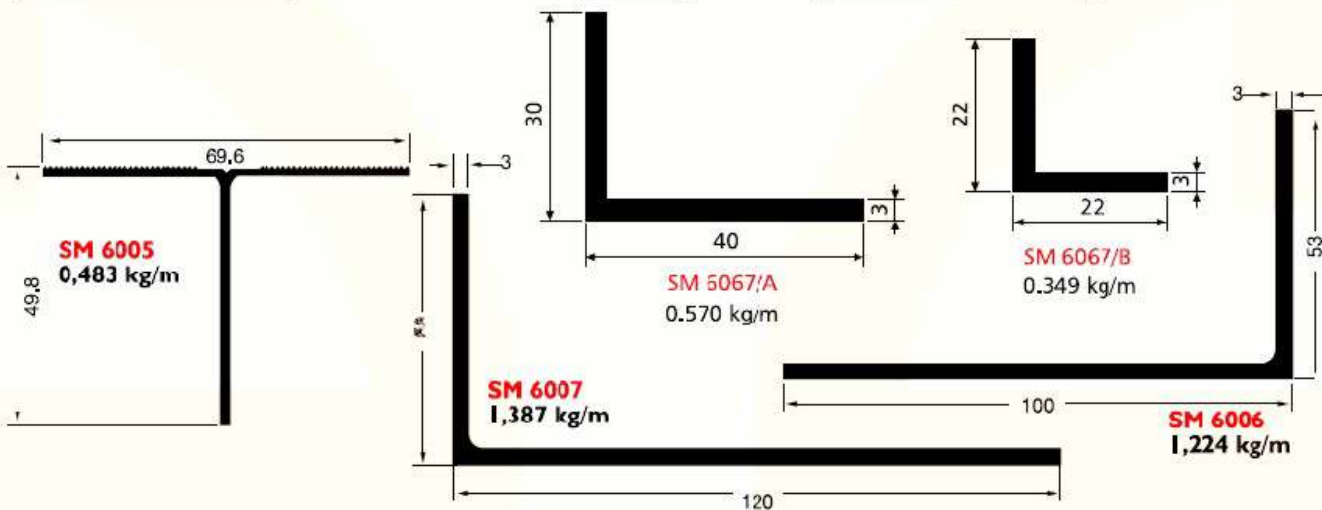
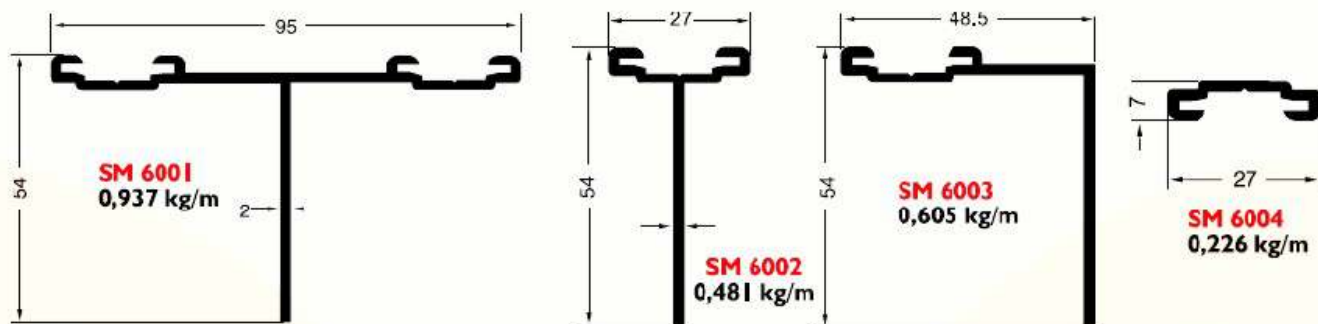
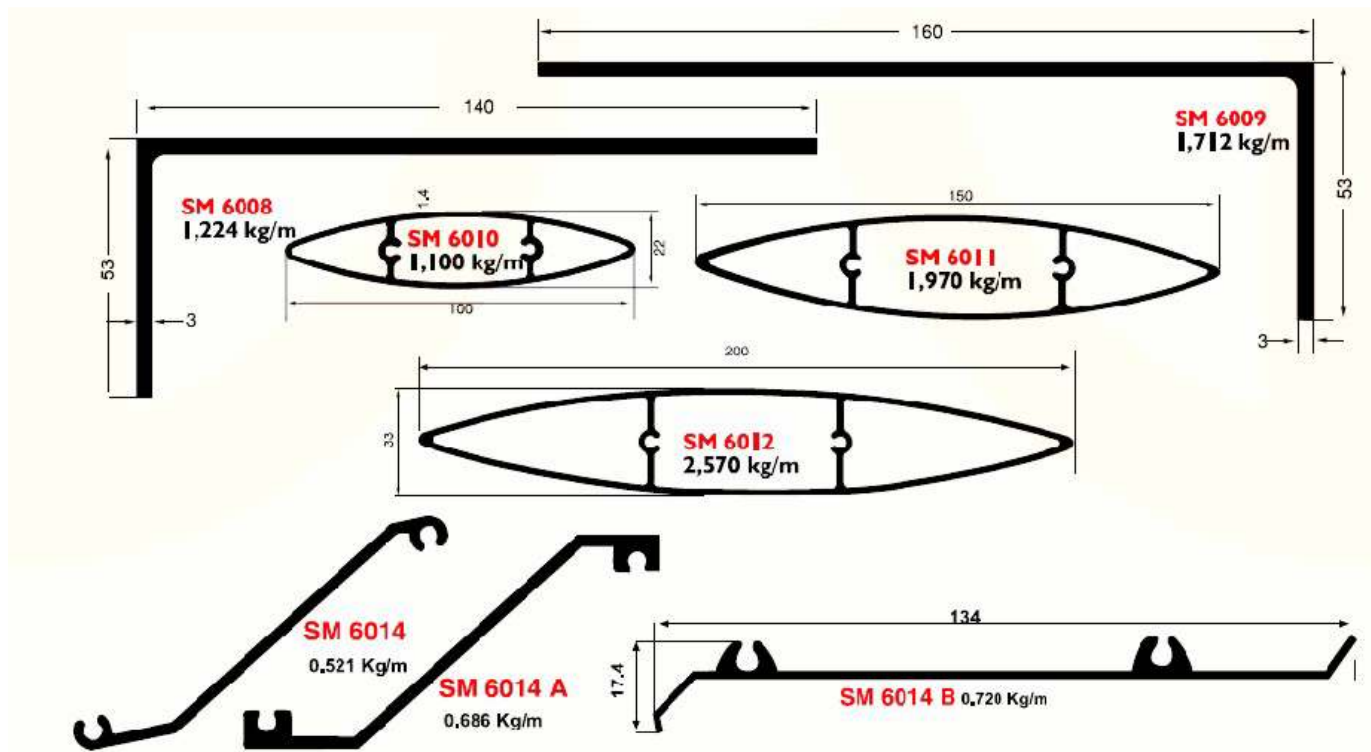

PROFILE pentru DILATARE

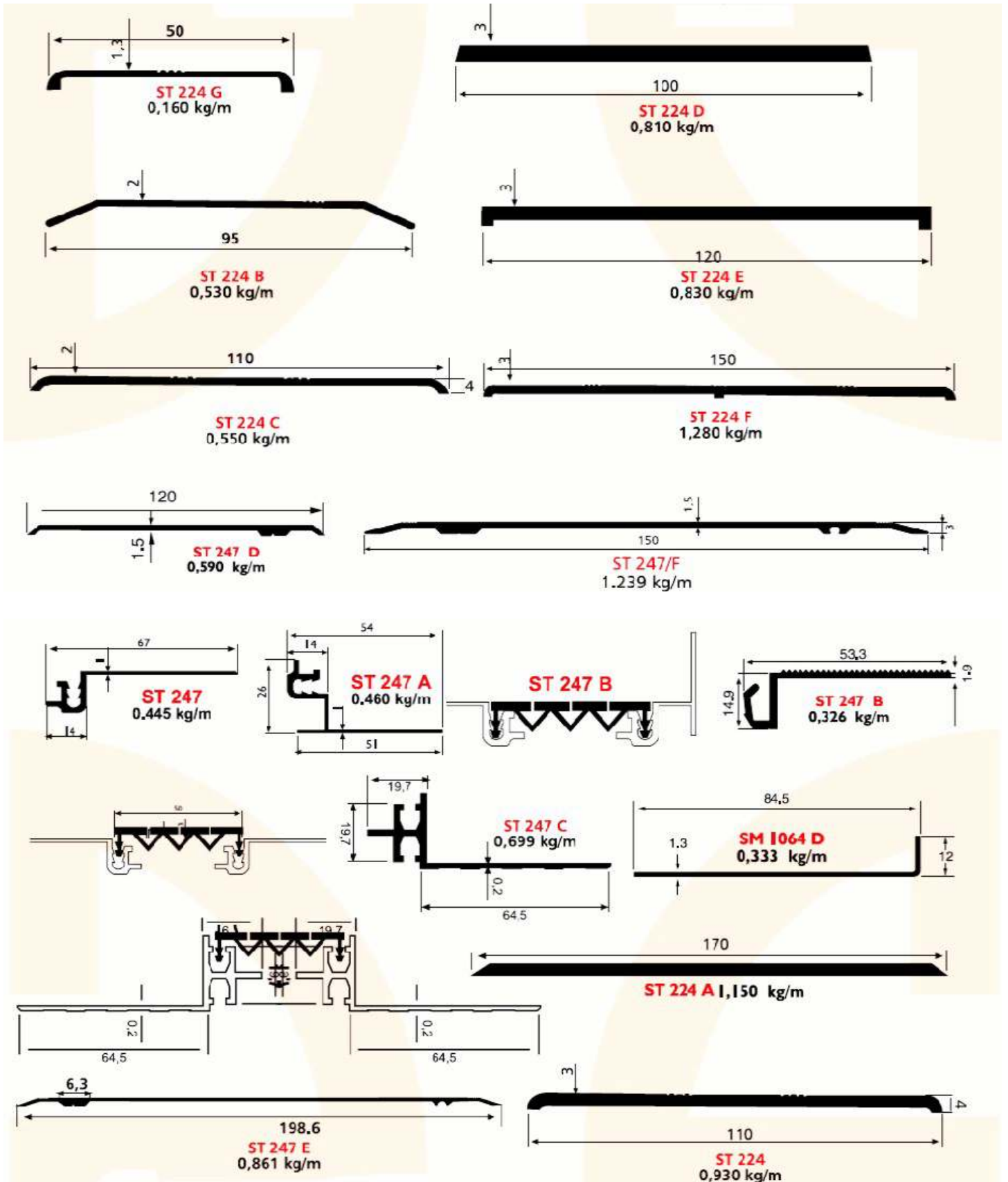

PROFILE POLICARBONAT



PROFILE si ACCESORII USI

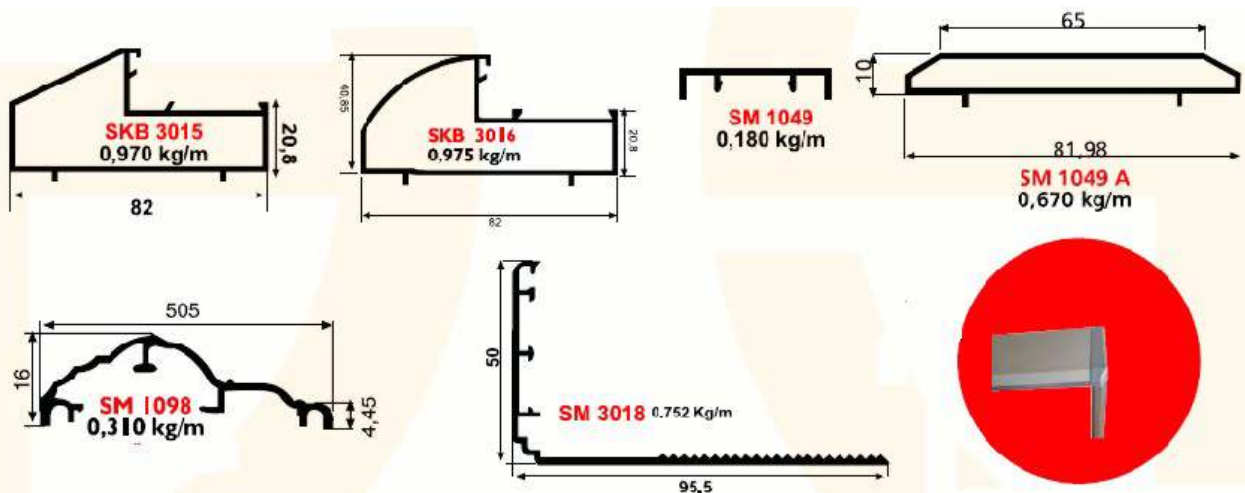
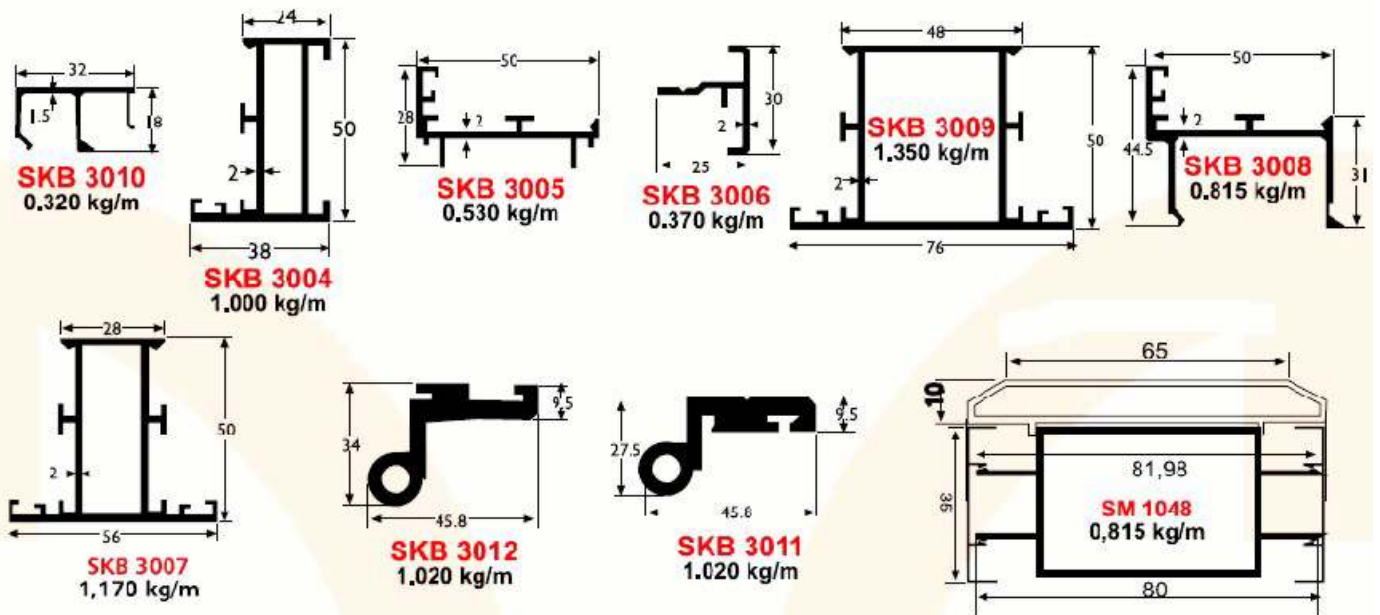

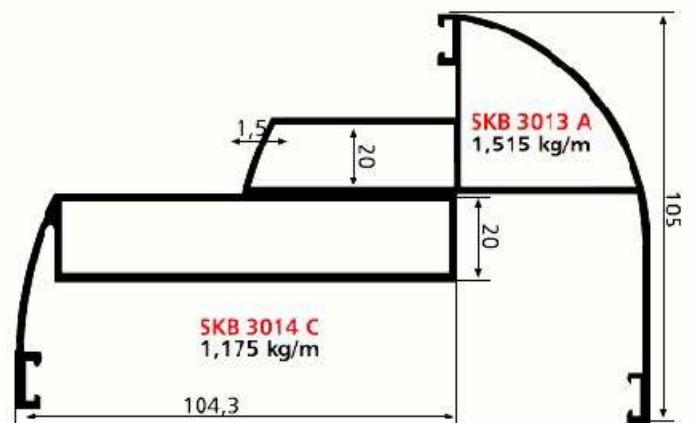
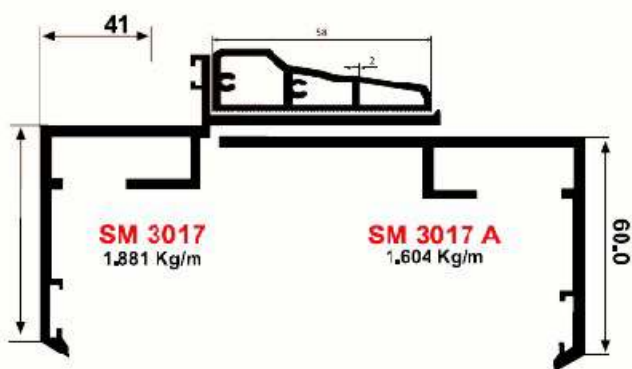
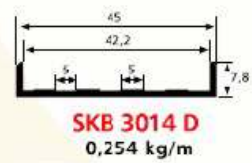
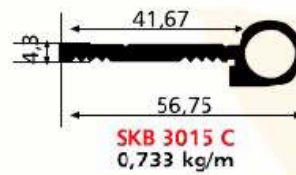
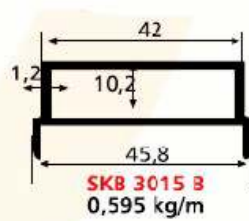
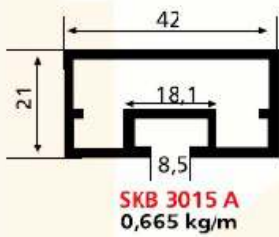
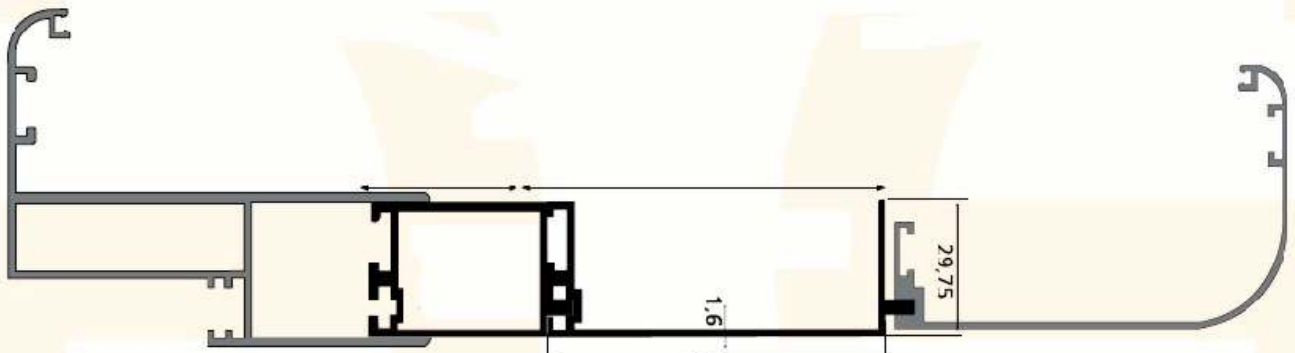
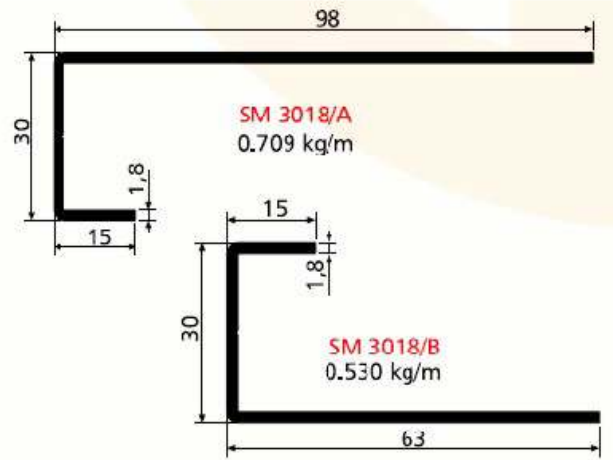
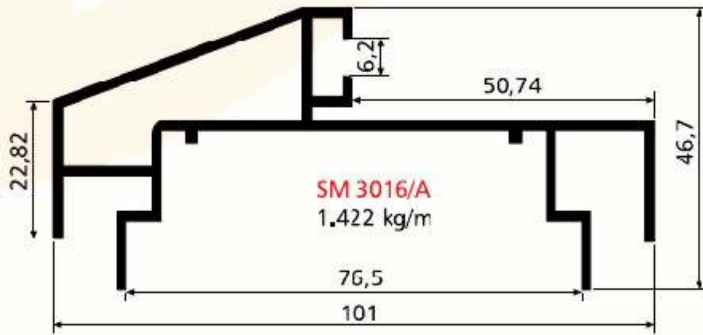

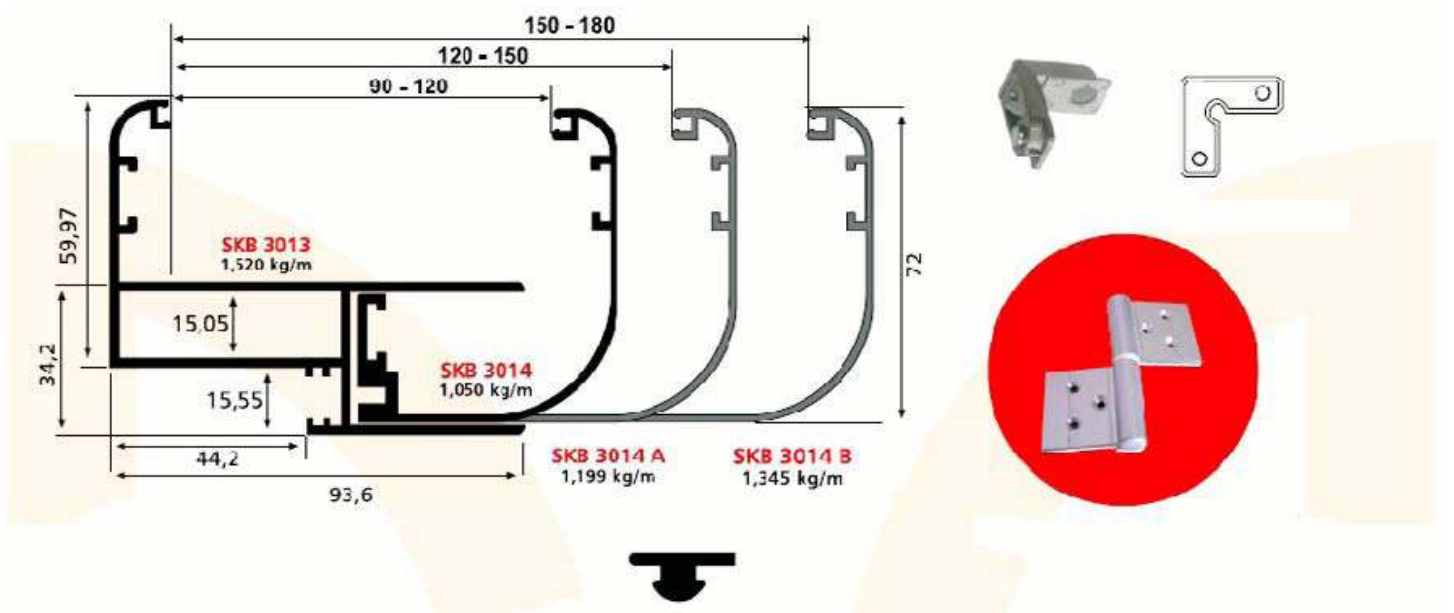
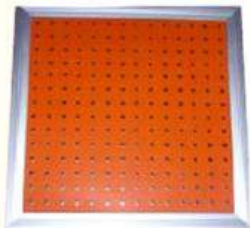

TABLE și CAPACE VENTILATIE



S Class Orange 514



S Class Silver 514



S Class Silver 515



Deri 458/PT



E Class Cobalt 1002



Deri 156/MH

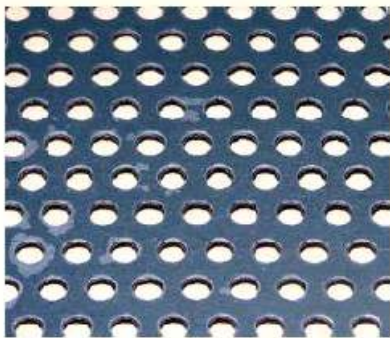
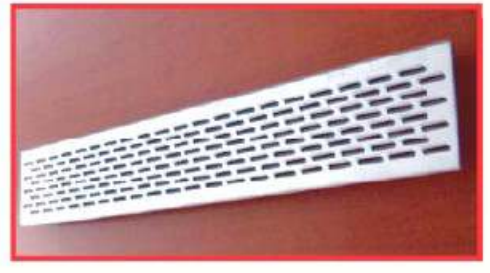

100x200
120x240



100x200
120x240

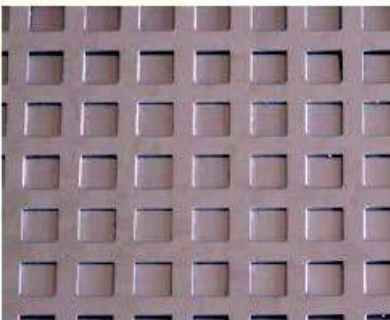

100x200
120x240



100x200
125x250

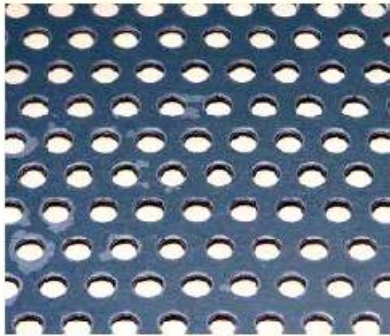

100x200
120x240



100x200
120x240

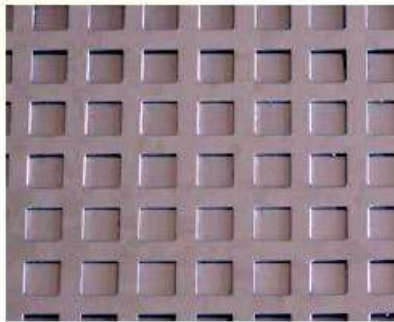

100x200
120x240



100x200
125x250

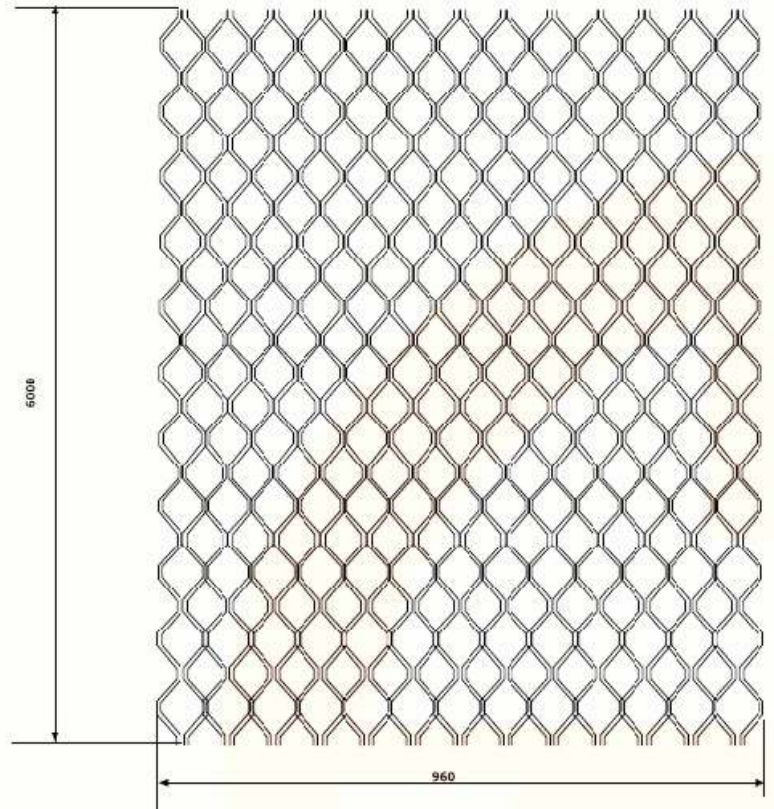
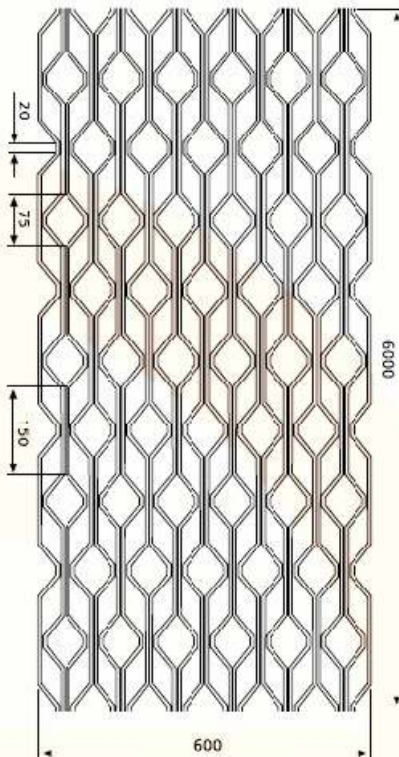

!!! ATENTIE !!!

Termeni si Conditii

Acest CATALOG cu PRODUSE este oferta noastra OFICIALA ,dar poate varia in functie de STOCUL si COMENZILE pe care firma noastra le proceseaza. De aceea ne rezervam dreptul de a MODIFICA si REACTUALIZA in prealabil lista cu produse fara a putea fi culpabilizati in vreun fel de eventualele neplaceri si prejudicii pe care posibilia clienti le-ar intampina in urma modificarilor efectuate .

Toate drepturile sunt inregistrate si rezervate exclusiv

(C) & (TM) EURO STAR ALUMINIU

s.r.l. BACAU